

Preface

Thank you for purchasing the H330 series AC drive developed by our company.

The H330 series AC drive is a general-purpose high-performance current vector control AC drive. It is an upgrade product based on H300 and can implement the control of asynchronous motor. It increases the user programmable function, background monitoring software and communication bus function. It is used to drive various automation production equipment involving textile, paper-making, wiredrawing, machine tool, packing, food, fan and pump.

This manual describes the correct use of the H330 series AC drive, including selection, parameter setting, commissioning, maintenance & inspection. Read and understand the manual before use and forward the manual to the end user.

Notes:

The drawings in the manual are sometimes shown without covers or protective guards. Remember to install the covers or protective guards as specified first, and then perform operations in accordance with the instructions.

The drawings in the manual are shown for description only and may not match the product you purchased.

The instructions are subject to change, without notice, due to product upgrade, specification modification as well as efforts to increase the accuracy and convenience of the manual.

Contact our agents or customer service center if you have problems during the use.

Product Checking

Upon unpacking, check:

Whether the nameplate model and AC drive ratings are consistent with your order. The box contains the AC drive, certificate of conformity, user manual and warranty card.

Whether the AC drive is damaged during transportation. If you find any omission or damage, contact our company or your supplier immediately.

First-time Use

For the users who use this product for the first time, read the manual carefully. If in doubt concerning some functions or performances, contact the technical support personnel of our company to ensure correct use.

Contents

CHAPTER 1 SAFETY INFORMATION AND PRECAUTIONS	- 1 -
1.1 SAFETY INFORMATION.....	- 1 -
1.2 GENERAL PRECAUTIONS.....	- 3 -
CHAPTER 2 PRODUCT INFORMATION	- 6 -
2.1 DESIGNATION RULES AND NAMEPLATE OF THE H330	- 6 -
2.2 ELECTRICAL SPECIFICATIONS OF THE H330.....	- 7 -
2.3 TECHNICAL SPECIFICATIONS.....	- 8 -
2.4 PHYSICAL APPEARANCE AND OVERALL DIMENSIONS OF THE H330	- 10 -
2.5 SELECTION OF BRAKING UNIT AND BRAKING RESISTOR.....	- 12 -
CHAPTER 3 MECHANICAL AND ELECTRICAL INSTALLATION	- 14 -
3.1 MECHANICAL INSTALLATION.....	- 14 -
3.2 ELECTRICAL INSTALLATION	- 15 -
3.2.1 SELECTION OF PERIPHERAL ELECTRICAL DEVICES	- 15 -
CHAPTER 4 OPERATION AND DISPLAY	- 21 -
4.1 OPERATION PANEL	- 21 -
4.2 VIEWING AND MODIFYING FUNCTION CODES	- 22 -
CHAPTER 5 FUNCTION CODE TABLE	- 23 -
5.1 STANDARD FUNCTION PARAMETERS.....	- 23 -
5.2 MONITORING PARAMETERS	- 42 -
CHAPTER 6 MAINTENANCE AND TROUBLESHOOTING	- 44 -
6.1 SOLUTIONS TO THE FAULTS OF THE H330	- 44 -
6.2 COMMON FAULTS AND SOLUTIONS	- 48 -
CHAPTER 7 COMMUNICATION PROTOCOL	- 49 -
7.1 ABOUT MODBUS COMMUNICATION PROTOCOL	- 49 -
7.2 APPLICATION.....	- 49 -
7.3 BUS STRUCTURE	- 49 -
7.4 DATA FORMAT	- 50 -
7.5 DEFINITION OF COMMUNICATION PARAMETER ADDRESSES	- 51 -
WARRANTY AGREEMENT	- 55 -
PRODUCT WARRANTY CARD	- 56 -

Chapter 1 Safety Information and Precautions

In this manual, the notices are graded based on the degree of danger:



DANGER indicates that failure to comply with the notice will result in severe personal injury or even death.



WARNING indicates that failure to comply with the notice will result in personal injury or property damage.

1.1 Safety Information

1.1.1 Before installation



DANGER

- Do not install the equipment if you find water seepage, component missing or damage upon unpacking.
- Do not install the equipment if the packing list does not conform to the product you received.



WARNING

- Handle the equipment with care during transportation to prevent damage to the equipment.
- Do not use the equipment if any component is damaged or missing.
Failure to comply will result in personal injury.
- Do not touch the components with your hands. Failure to comply will result in static electricity damage.

1.1.2 During installation



DANGER

- Install the equipment on incombustible objects such as metal, and keep it away from combustible materials. Failure to comply may result in a fire.
- Do not loosen the fixed screws of the components, especially the screws with red mark.



WARNING

- Do not drop wire end or screw into the AC drive. Failure to comply will result in damage to the AC drive.
- Install the AC drive in places free of vibration and direct sunlight.
- When two AC drives are laid in the same cabinet, arrange the installation positions properly to ensure the cooling effect.

1.1.3 At wiring



DANGER

- Wiring must be performed only by qualified personnel under instructions described in this manual. Failure to comply may result in unexpected accidents.
- A circuit breaker must be used to isolate the power supply and the AC drive. Failure to comply may result in a fire.
- Ensure that the power supply is cut off before wiring. Failure to comply may result in electric shock.
- Tie the AC drive to ground properly by standard. Failure to comply may result in

electric shock.



WARNING

- Never connect the power cables to the output terminals (U, V, W) of the AC drive. Pay attention to the marks of the wiring terminals and ensure correct wiring. Failure to comply will result in damage to the AC drive.
- Never connect the braking resistor between the DC bus terminals (+) and (-). Failure to comply may result in a fire.
- Use wire sizes recommended in the manual. Failure to comply may result in accidents.
- Use a shielded cable for the encoder, and ensure that the shielding layer is reliably grounded.

1.1.4 Before power-on



DANGER

- Check that the following requirements are met:
 - The voltage class of the power supply is consistent with the rated voltage class of the AC drive.
 - The input terminals (R, S, T) and output terminals (U, V, W) are properly connected.
 - No short-circuit exists in the peripheral circuit.
 - The wiring is secured.

Failure to comply will result in damage to the AC drive

- Do not perform the voltage resistance test on any part of the AC drive because such test has been done in the factory. Failure to comply will result in accidents.



WARNING

- Cover the AC drive properly before power-on to prevent electric shock.
- All peripheral devices must be connected properly under the instructions described in this manual. Failure to comply will result in accidents

1.1.5 After power-on



DANGER

- Do not open the AC drive's cover after power-on. Failure to comply may result in electric shock.
- Do not touch any I/O terminal of the AC drive. Failure to comply may result in electric shock.



WARNING

- Do not touch the rotating part of the motor during the motor auto-tuning or running. Failure to comply will result in accidents.
- Do not change the default settings of the AC drive. Failure to comply will result in damage to the AC drive.

1.1.6 During operation



DANGER

- Do not touch the fan or the discharging resistor to check the temperature. Failure to comply will result in personal burnt.
- Signal detection must be performed only by qualified personnel during operation. Failure to comply will result in personal injury or damage to the AC drive.



WARNING

- Avoid objects falling into the AC drive when it is running. Failure to comply will result in damage to the AC drive.
- Do not start/stop the AC drive by turning the contactor ON/OFF.
- Failure to comply will result in damage to the AC drive.

1.1.7 During maintenance



- Repair or maintenance of the AC drive may be performed only by qualified personnel. Failure to comply will result in personal injury or damage to the AC drive.
- Do not repair or maintain the AC drive at power-on. Failure to comply will result in electric shock.
- Repair or maintain the AC drive only ten minutes after the AC drive is powered off. This allows for the residual voltage in the capacitor to discharge to a safe value. Failure to comply will result in personal injury.
- Ensure that the AC drive is disconnected from all power supplies before starting repair or maintenance on the AC drive.
- Set and check the parameters again after the AC drive is replaced.
- All the pluggable components must be plugged or removed only after power-off.
- The rotating motor generally feeds back power to the AC drive. As a result, the AC drive is still charged even if the motor stops, and the power supply is cut off. Thus ensure that the AC drive is disconnected from the motor before starting repair or maintenance on the AC drive.

1.2 General Precautions

1.2.1 Motor insulation test

Perform the insulation test when the motor is used for the first time, or when it is reused after being stored for a long time, or in a regular check-up, in order to prevent the poor insulation of motor windings from damaging the AC drive. The motor must be disconnected from the AC drive during the insulation test. A 500-V mega-Ohm meter is recommended for the test. The insulation resistance must not be less than 5MΩ.

1.2.2 Thermal protection of motor

If the rated capacity of the motor selected does not match that of the AC drive, especially when the AC drive's rated power is greater than the motor's, adjust the motor protection parameters on the operation panel of the AC drive or install a thermal relay in the motor circuit for protection.

1.2.3 Running at over 50 Hz

The AC drive provides frequency output of 0 to 1000 Hz (Up to 300 Hz is supported if the AC drive runs in SVC mode). If the AC drive is required to run at over 50 Hz, consider the capacity of the machine.

1.2.4 Vibration of mechanical device

The AC drive may encounter the mechanical resonance point at some output frequencies, which can be avoided by setting the skip frequency.

1.2.5 Motor heat and noise

The output of the AC drive is pulse width modulation (PWM) wave with certain harmonic frequencies, and therefore, the motor temperature, noise, and vibration are slightly greater than

those when the AC drive runs at power frequency (50 Hz).

1.2.6 Voltage-sensitive device or capacitor on output side of the AC drive

Do not install the capacitor for improving power factor or lightning protection voltage-sensitive resistor on the output side of the AC drive because the output of the AC drive is PWM wave. Otherwise, the AC drive may suffer transient overcurrent or even be damaged.

1.2.7 Contactor at the I/O terminal of the AC drive

When a contactor is installed between the input side of the AC drive and the power supply, the AC drive must not be started or stopped by switching the contactor on or off. If the AC drive has to be operated by the contactor, ensure that the time interval between switching is at least one hour since frequent charge and discharge will shorten the service life of the capacitor inside the AC drive.

When a contactor is installed between the output side of the AC drive and the motor, do not turn off the contactor when the AC drive is active. Otherwise, modules inside the AC drive may be damaged.

1.2.8 When external voltage is out of rated voltage range

The AC drive must not be used outside the allowable voltage range specified in this manual. Otherwise, the AC drive's components may be damaged. If required, use a corresponding voltage step-up or step-down device.

1.2.9 Prohibition of three-phase input changed into two-phase input

Do not change the three-phase input of the AC drive into two-phase input. Otherwise, a fault will result or the AC drive will be damaged.

1.2.10 Surge suppressor

The AC drive has a built-in voltage dependent resistor (VDR) for suppressing the surge voltage generated when the inductive loads (electromagnetic contactor, electromagnetic relay, solenoid valve, electromagnetic coil and electromagnetic brake) around the AC drive are switched on or off. If the inductive loads generate a very high surge voltage, use a surge suppressor for the inductive load or also use a diode.

1.2.11 Altitude and de-rating

In places where the altitude is above 1000 m and the cooling effect reduces due to thin air, it is necessary to de-rate the AC drive. Contact our company for technical support.

1.2.12 Some special usages

If wiring that is not described in this manual such as common DC bus is applied, contact the agent or our company for technical support.

1.2.13 Disposal

The electrolytic capacitors on the main circuits and PCB may explode when they are burnt. Poisonous gas is generated when the plastic parts are burnt. Treat them as ordinary industrial waste.

1.2.14 Adaptable Motor

1) The standard adaptable motor is adaptable four-pole squirrel-cage asynchronous induction motor. For other types of motor, select a proper AC drive according to the rated motor current.

2) The cooling fan and rotor shaft of non-variable-frequency motor are coaxial, which results in reduced cooling effect when the rotational speed declines. If variable speed is required, add a more powerful fan or replace it with variable-frequency motor in applications where the motor overheats easily.

3) The standard parameters of the adaptable motor have been configured inside the AC drive. It is still necessary to perform motor auto-tuning or modify the default values based on actual conditions. Otherwise, the running result and protection performance will be affected.

4) The AC drive may alarm or even be damaged when short-circuit exists on cables or inside the motor. Therefore, perform insulation short-circuit test when the motor and cables are newly installed or during routine maintenance. During the test, make sure that the AC drive is disconnected from the tested parts.

Chapter 2 Product Information

2.1 Designation Rules and Nameplate of the H330

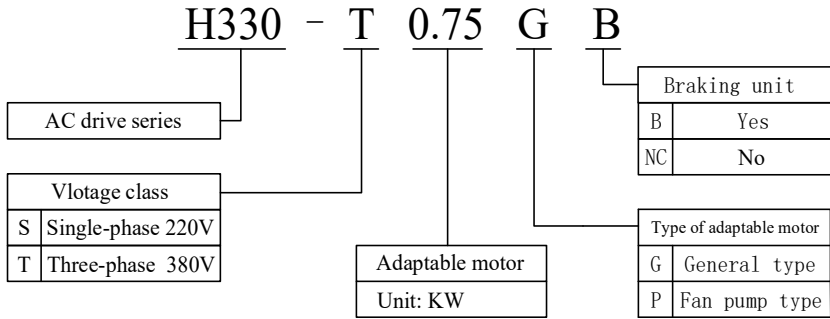
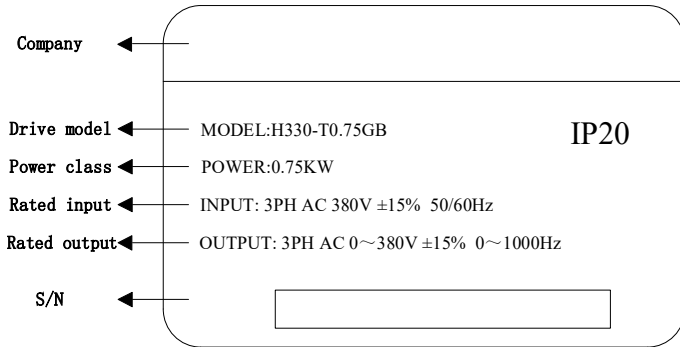

Figure 2-1 Designation rules and nameplate of the H330



2.2 Electrical Specifications of the H330

Table 2-1 Models and technical data of the H330

Model	Power Capacity kVA	Input Current A	Output Current A	Adaptable Motor kW HP	
Single-phase: 220V, 50/60Hz					
H330-2S0.75GB	1.5	8.2	4.0	0.75	1
H330-2S1.5GB	3.0	14.0	7.0	1.5	2
H330-2S2.2GB	4.0	23.0	9.6	2.2	3
Three-phase: 380V, 50/60Hz					
H330-4T0.75GB	1.5	3.4	2.1	0.75	1
H330-4T1.5GB	3.0	5.0	3.8	1.5	2
H330-4T2.2GB	4.0	5.8	5.1	2.2	3
H330-4T4GB	5.9	10.5	9.0	3.7	5
H330-4T5.5GB	8.9	14.6	13.0	5.5	7.5
H330-4T7.5GB	11.0	20.5	17.0	7.5	10
H330-4T11GB-B	17.0	26.0	25.0	11.0	15
H330-4T11GB	17.0	26.0	25.0	11.0	15
H330-4T15GB	21.0	35.0	32.0	15.0	20
H330-4T18.5GB	24.0	38.5	37.0	18.5	25
H330-4T22GB	30.0	46.5	45.0	22	30
H330-4T30GB	40.0	62.0	60.0	30	40
H330-4T37G	57.0	76.0	75.0	37	50
H330-4T45G	69.0	92.0	91.0	45	60
H330-4T55G	85.0	113.0	112.0	55	70
H330-4T75G	114.0	157.0	150.0	75	100
H330-4T90G	134.0	180.0	176.0	90	125
H330-4T110G	160.0	214.0	210.0	110	150
H330-4T132G	192.0	256.0	253.0	132	175
H330-4T160G	231.0	307.0	304.0	160	210
H330-4T185G	240.0	343.0	340.0	185	240
H330-4T200G	250.0	385.0	377.0	200	260
H330-4T220G	280.0	430.0	426.0	220	300
H330-4T250G	355.0	468.0	465.0	250	350
H330-4T280G	396.0	525.0	520.0	280	370
H330-4T315G	445.0	590.0	585.0	315	500
H330-4T355G	500.0	665.0	650.0	355	420
H330-4T400G	565.0	785.0	725.0	400	530
H330-4T450G	625.0	850.0	820.0	450	600

2.3 Technical Specifications

Table 2-2 Technical specifications of the H330

Item		Specifications
Standard functions	Carrier frequency	0.5–16 kHz The carrier frequency is automatically adjusted based on the load features.
	Input frequency resolution	Digital setting: 0.01 Hz Analog setting: maximum frequency x 0.025%
	Control mode	Sensorless flux vector control (SVC) Voltage/Frequency (V/F) control
	Startup torque	G type: 0.5 Hz/150% (SVC);
	Speed range	1:100 (SVC)
	Speed stability accuracy	± 0.5% (SVC)
	Torque control accuracy	± 5% (SVC)
	Overload capacity	G type: 60s for 150% of the rated current, 3s for 180% of the rated current
	Torque boost	Fixed boost Customized boost 0.1%–30.0%
	V/F curve	Straight-line V/F curve Multi-point V/F curve N-power V/F curve (1.2-power, 1.4-power, 1.6-power, 1.8-power, square)
	V/F separation	Two types: complete separation; half separation
	Ramp mode	Straight-line ramp S-curve ramp Four groups of acceleration/deceleration time with the range of 0.0–6500.0s
	DC braking	DC braking frequency: 0.00 Hz to maximum frequency Braking time: 0.0–36.0s Braking action current value: 0.0%–100.0%
	JOG control	JOG frequency range: 0.00–50.00 Hz JOG acceleration/deceleration time: 0.0–6500.0s
	Onboard multiple preset speeds	It implements up to 16 speeds via the simple PLC function or combination of DI terminal states.
	Onboard PID	It realizes process-controlled closed loop control system easily.
	Auto voltage regulation (AVR)	It can keep constant output voltage automatically when the mains voltage changes.
Overvoltage/Overcurrent stall control	The current and voltage are limited automatically during the running process so as to avoid frequent tripping due to overvoltage/overcurrent.	
Torque limit and control	It can limit the torque automatically and prevent frequent over current tripping during the running process.	
Individualized functions	High performance	Control of asynchronous motor are implemented through the high-performance current vector control technology.
	Power dip ride through	The load feedback energy compensates the voltage reduction so that the AC drive can continue to run for a short time.
	Rapid current limit	It helps to avoid frequent overcurrent faults of the AC drive.
	Virtual I/Os	Five groups of virtual DI/Dos can realize simple logic control.
	Timing control	Time range: 0.0–6500.0 minutes
	Supports communication	It supports communication via Modbus-RTU or other type.
RUN	Running command source	Operation panel Control terminals Serial communication port You can perform switchover between these sources in various ways.
	Frequency source	There are a total of 10 frequency sources, such as digital setting, analog voltage setting, analog current setting, pulse setting and serial communication port setting.

Item		Specifications
		You can perform switchover between these sources in various ways.
	Auxiliary frequency source	There are ten auxiliary frequency sources. It can implement fine tuning of auxiliary frequency and frequency synthesis.
	Input terminal	6 digital input (DI) terminals, one of which supports up to 100 kHz high-speed pulse input 2 analog input (AI) terminals, one of which only supports 0–10 V voltage input and the other supports 0–10 V voltage input or 4–20 mA current input
	Output terminal	1 high-speed pulse output terminal (open-collector) that supports 0–100 kHz square wave signal output 1 digital output (DO) terminal 2 relay output terminal 2 analog output (AO) terminal that supports 0–20 mA current output or 0–10 V voltage output
Display and operation	LED display	It displays the parameters.
	Incremental encoder	Used to modify parameters.
	Copy parameters	Upload parameters or download parameters.
	Key locking and function selection	It can lock the keys partially or completely and define the function range of some keys so as to prevent mis-function.
Environment	Installation location	Indoor, free from direct sunlight, dust, corrosive gas, combustible gas, oil smoke, vapour, drip or salt.
	Altitude	Lower than 1000 m
	Ambient temperature	-10°C to +40°C (de-rated if the ambient temperature is between 40°C and 50°C)
	Humidity	Less than 95%RH, without condensing
	Vibration	Less than 5.9 m/s ² (0.6 g)
	Storage temperature	-20°C to +60°C
	IP level	IP20
	Pollution degree	PD2
Power distribution system	TN , TT	

2.4 Physical Appearance and Overall Dimensions of the H330

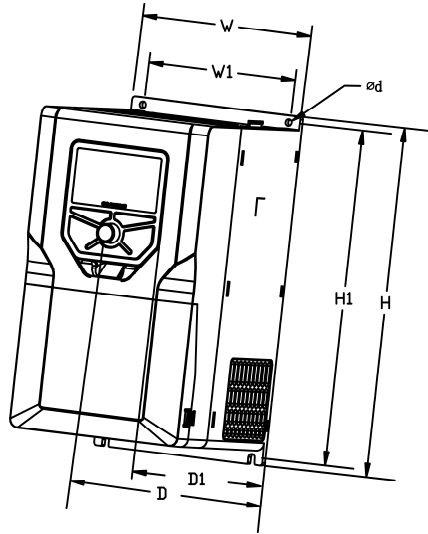

Figure2-3 Physical appearance and overall dimensions of the H330 (plastic housing)

Model	Overall Dimensions (mm)				Mounting Hole (mm)		Mounting Hole Diameter (mm)	Weight (kg)
	H	W	D	D1	H1	W1		
H330-2S0.75GB	187	88	140	131	177	73	5	1.4
H330-2S1.5GB								
H330-2S2.2GB								
H330-2T0.75GB								
H330-2T1.5GB								
H330-2T2.2GB	207	100	149	140	197	85	5	1.7
H330-2T4GB								
H330-4T5.5GB								
H330-4T7.5GB	247	130	169	159	238	113	5	2.8
H330-4T11GB-B								

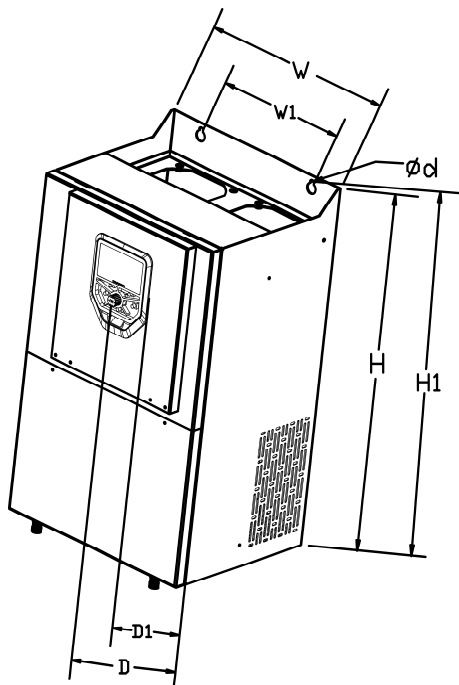

Figure 2-4 Physical appearance and overall dimensions of the H330 (sheet metal housing)

Model	Overall Dimensions (mm)				Mounting Hole (mm)		Mounting Hole Diameter (mm)	Weight (kg)
	H	W	D	D1	H1	W1		
H330-4T11GB	348	182	203	190	331	156	6	8.5
H330-4T15GB								
H330-4T18.5GB								
H330-4T22GB	373	221	203	190	356	156	6	10
H330-4T30GB								
H330-4T37G	435	256	222	207	419	170	6	13.6
H330-4T45G								
H330-4T55G	544	310	276	263	524	241	10	23.2
H330-4T75G								
H330-4T90G								
H330-4T110G	580	358	326	313	559	270	10	38.7
H330-4T132G								
H330-4T160G	870	500	355	342	837	320	10	82.2
H330-4T185G								
H330-4T200G								
H330-4T220G	Developing							
H330-4T250G								
H330-4T280G								
H330-4T315G								
H330-4T355G								
H330-4T400G								
H330-4T450G								
H330-4T450G								

2.4.2 Physical Dimensions of External Operation Panel

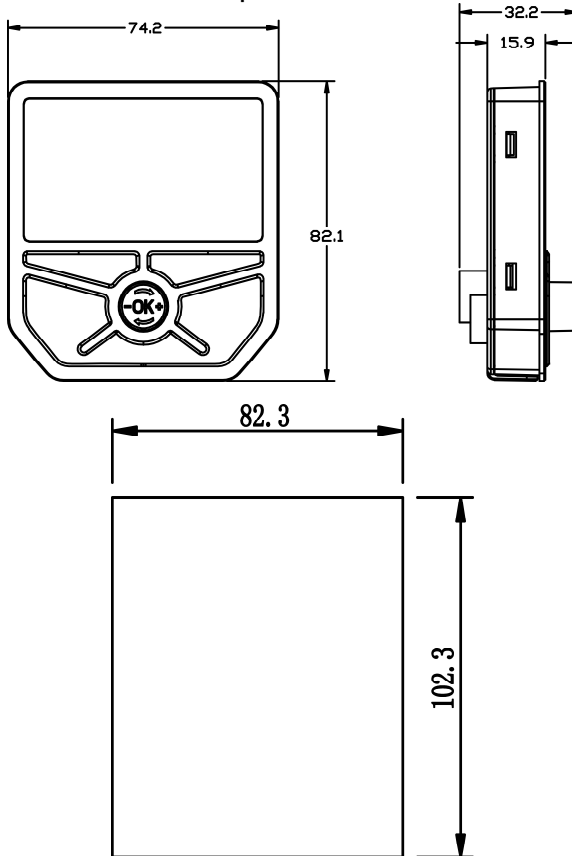

Figure 2-6 Physical dimensions of external operation panel with pedestal (Unit: mm)

2.5 Selection of Braking Unit and Braking Resistor

Table 2-7 Recommended values of braking resistor

Model	Recommended Power	Recommended Resistance	Braking Unit	Remark
H330-2S0.75GB	80W	≥150Ω	Built-in	
H330-2S1.5GB	100W	≥100Ω	Built-in	
H330-2S2.2GB	100W	≥70Ω	Built-in	
H330-4T0.75GB	150W	≥300Ω	Built-in	
H330-4T1.5GB	150W	≥220Ω	Built-in	
H330-4T2.2GB	250W	≥200Ω	Built-in	
H330-4T4GB	300W	≥130Ω	Built-in	
H330-4T5.5GB	400W	≥90Ω	Built-in	
H330-4T7.5GB	500W	≥65Ω	Built-in	
H330-4T11GB-B	800W	≥43Ω	Built-in	
H330-4T11GB	800W	≥43Ω	Built-in	

Model	Recommended Power	Recommended Resistance	Braking Unit	Remark
H330-4T15GB	1000W	≥32Ω	Built-in	
H330-4T18.5GB	1300W	≥25Ω	Built-in	
H330-4T22GB	1500W	≥22Ω	Built-in	
H330-4T30GB	2500W	≥16Ω	Built-in	
H330-4T37G	3.7 kW	≥16.0Ω	External	
H330-4T45G	4.5 kW	≥16Ω	External	
H330-4T55G	5.5 kW	≥8Ω	External	
H330-4T75G	7.5 kW	≥8Ω	External	
H330-4T90G	4.5 kW×2	≥8Ω×2	External	
H330-4T110G	5.5 kW×2	≥8Ω×2	External	
H330-4T132G	6.5 kW×2	≥8Ω×2	External	
H330-4T160G	16kW	≥2.5Ω	External	
H330-4T185G	20kW	≥2.5Ω	External	
H330-4T200G	20 kW	≥2.5Ω	External	
H330-4T220G	22 kW	≥2.5Ω	External	
H330-4T250G	12.5 kW×2	≥2.5Ω×2	External	
H330-4T280G	14kW×2	≥2.5Ω×2	External	
H330-4T315G	16kW×2	≥2.5Ω×2	External	
H330-4T355G	17kW×2	≥2.5Ω×2	External	
H330-4T400G	14 kW×3	≥2.5Ω×3	External	
H330-4T450G	16 kW×3	≥2.5Ω×3	External	

" x 2" indicates that two braking units with their respective braking resistor are connected in parallel.

" x 3" means the same.

The braking resistor model is dependent on the generation power of the motor in the actual system and is also related to the system inertia, deceleration time and potential energy load. For systems with high inertia, and/or rapid deceleration times, or frequent braking sequences, the braking resistor with higher power and lower resistance value should be selected.

2.6.1 Physical Dimensions of External DC Reactor

The motor and load's regenerative energy is almost completely consumed on the braking resistor when braking.

According to the formula $U \times U/R = P_b$:

U refers to the braking voltage at system stable braking.

Different systems select different braking voltages. The 380 VAC system usually selects 700 V braking voltage.

P_b refers to the braking power.

2.6.2 Selection of Power of Braking Resistor

In theory, the power of the braking resistor is consistent with the braking power. But in consideration that the de-rating is 70%, you can calculate the power of the braking resistor according to the formula $0.7 \times P_r = P_b \times D$.

P_r refers to the power of resistor.

D refers to the braking frequency (percentage of the regenerative process to the whole working process)

Chapter 3 Mechanical and Electrical Installation

3.1 Mechanical Installation

3.1.1 Installation Environment Requirements

Item	Requirements
Ambient temperature	-10°C to +50°C
Heat dissipation	Install the AC drive on the surface of an incombustible object, and ensure that there is sufficient space around for heat dissipation. Install the AC drive vertically on the support using screws.
Mounting location	Free from direct sunlight, high humidity and condensation
	Free from corrosive, explosive and combustible gas
	Free from oil dirt, dust and metal powder
Vibration	Less than 0.6 g Far away from the punching machine or the like
Protective enclosure	The H330 series AC drives of plastic housing are the whole unit built-in products operated through remote control and need to be installed in the final system. The final system must have the required fireproof cover, electrical protective cover and mechanical protective cover, and satisfy the regional laws & regulations and related IEC requirements.

3.1.2 Mechanical Installation Method and Process

- 1) Reserve the installation clearances as specified in Figure 3-1 to ensure sufficient space for heat dissipation. Take heat dissipation of other parts in the cabinet into consideration.
- 2) Install the AC drives upright to facilitate heat dissipation. If multiple AC drives are installed in the cabinet, install them side by side. If one row of AC drives need to be installed above another row, install an insulation guide plate, as shown in Figure 3-2.
- 3) Use incombustible hanging bracket.
- 4) In scenarios with heavy metal powder, install the heatsink outside the cabinet, and ensure that the room inside the fully-sealed cabinet is as large as possible.

3.2 Electrical Installation

3.2.1 Selection of Peripheral Electrical Devices

Table 3-1 Selection of peripheral electrical devices of the H330

Model	MCCB (A)	Contactora (A)	Cable of Input Side Main Circuit (mm ²)	Cable of Output Side Main Circuit (mm ²)	Cable of Control Circuit (mm ²)
H330-2S0.75GB	16	10	2.5	2.5	1.0
H330-2S1.5GB	20	16	4.0	2.5	1.0
H330-2S2.2GB	32	20	6.0	4.0	1.0
H330-4T0.75GB	10	10	2.5	2.5	1.0
H330-4T1.5GB	16	10	2.5	2.5	1.0
H330-4T2.2GB	16	10	2.5	2.5	1.0
H330-4T4GB	25	16	4.0	4.0	1.0
H330-4T5.5GB	32	25	4.0	4.0	1.0
H330-4T7.5GB	40	32	4.0	4.0	1.0
H330-4T11GB	63	40	4.0	4.0	1.0
H330-4T15GB	63	40	6.0	6.0	1.0
H330-4T18.5GB	100	63	6	6	1.5
H330-4T22GB	100	63	10	10	1.5
H330-4T30G	125	100	16	10	1.5
H330-4T37G	160	100	16	16	1.5
H330-4T45G	200	125	25	25	1.5
H330-4T55G	200	125	35	25	1.5
H330-4T75G	250	160	50	35	1.5
H330-4T90G	250	160	70	35	1.5
H330-4T110G	350	350	120	120	1.5
H330-4T132G	400	400	150	150	1.5
H330-4T160G	500	400	185	185	1.5
H330-4T185G	600	600	150*2	150*2	1.5
H330-4T200G	600	600	150*2	150*2	1.5
H330-4T220G	600	600	150*2	150*2	1.5
H330-4T250G	800	600	185*2	185*2	1.5
H330-4T280G	800	800	185*2	185*2	1.5
H330-4T315G	800	800	150*3	150*3	1.5
H330-4T355G	800	800	150*4	150*4	1.5
H330-4T400G	1000	1000	150*4	150*4	1.5
H330T450G	1000	1000	150*4	150*4	1.5

3.2.3 Wiring of AC Drive Control Circuit

Figure 3-14 Wiring mode of the AC drive control circuit

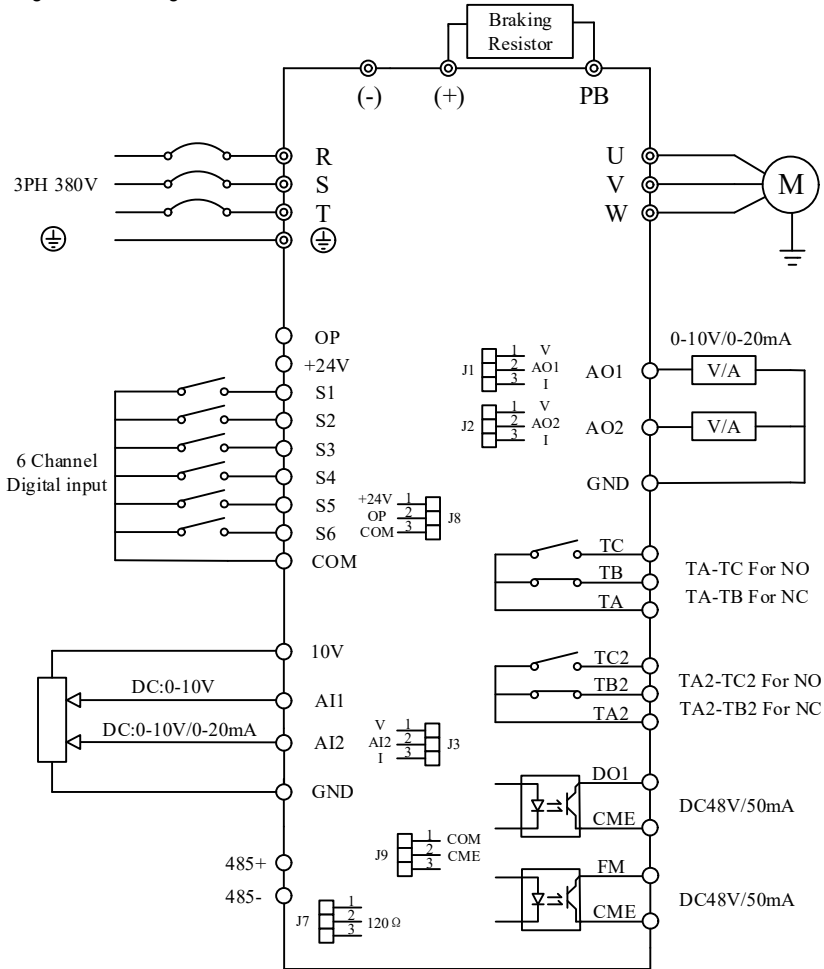

3.2.4 Description of Main Circuit Terminals

Description of main circuit terminals of single-phase AC drive.

Terminal	Name	Description
L, N	Single-phase power supply input terminals	Connect to the single-phase 220 VAC power supply.
(+), PB	Connecting terminals of braking resistor	Connect to a braking resistor.
U, V, W	AC drive output terminals	Connect to a three-phase motor.
	Grounding terminal	Must be grounded.

Description of main circuit terminals of three-phase AC drive.

Terminal	Name	Description
R, S, T	Three-phase power supply input terminals	Connect to the three-phase AC power supply
(+), (-)	Positive and negative terminals of DC bus	Common DC bus input point Connect the external braking unit to the AC drive of 18.5 kW and above (220 V) and 37 kW and above (other voltage classes).
(+), PB	Connecting terminals of braking resistor	Connect to the braking resistor for the AC drive of 15 kW and below (220 V) and 30 kW and below (other voltage classes).
P, (+)	Connecting terminals of external reactor	Connect to an external reactor.
U, V, W	AC drive output terminals	Connect to a three-phase motor.
	Grounding terminal	Must be grounded.

Precautions on the Wiring:

(1) Power input terminals L1, L2 or R, S, T

The cable connection on the input side of the AC drive has no phase sequence requirement.

The specification and installation method of external power cables must comply with the local safety regulations and related IEC standards.

Use copper conductors of a proper size as power cables according to the recommended values in section 8.3.

(2) DC bus terminals (+), (-)

Terminals (+) and (-) of DC bus have residual voltage after the AC drive is switched off. After indicator CHARGE goes off, wait at least 10 minutes before touching the equipment. Otherwise, you may get electric shock.

connecting external braking components for the AC drive of 18.5 kW and above (220 V) and 37 kW and above (other voltage classes), do not reverse poles (+) and (-). Otherwise, it may damage the AC drive and even cause a fire.

The cable length of the braking unit shall be no longer than 10 m. Use twisted pair wire or pair wires for parallel connection.

Do not connect the braking resistor directly to the DC bus. Otherwise, it may damage the AC drive and even cause fire.

(3) Braking resistor connecting terminals (+), PB

The connecting terminals of the braking resistor are effective only for the AC configured with the built-in braking unit.

The cable length of the braking resistor shall be less than 5 m. Otherwise, it may damage the

AC drive.

(4) External reactor connecting terminals P, (+)

For the AC drive of 37 kW and above (220 V) and 75 kW and above (other voltage classes), remove the jumper bar across terminals P and (+) and install the reactor between the two terminals.

(5) AC drive output terminals U, V, W

The specification and installation method of external power cables must comply with the local safety regulations and related IEC standards.

Use copper conductors of a proper size as power cables according to the recommended values in section 8.3.

The capacitor or surge absorber cannot be connected to the output side of the AC drive. Otherwise, it may cause frequent AC drive fault or even damage the AC drive.

If the motor cable is too long, electrical resonance will be generated due to the impact of distributed capacitance. This will damage the motor insulation or generate higher leakage current, causing the AC drive to trip in overcurrent protection. If the motor cable is greater than 100 m long, an AC output reactor must be installed close to the AC drive.

(6) Terminal  PE

This terminal must be reliably connected to the main earthing conductor. Otherwise, it may cause electric shock, mal-function or even damage to the AC drive.

Do not connect the earthing terminal to the neutral conductor of the power supply.

The impedance of the PE conductor must be able to withstand the large short-circuit current that may arise when a fault occurs.

Select the size of the PE conductor according to the following table:

Cross-sectional Area of a Phase Conductor (S)	Min. Cross-sectional Area of Protective Conductor (Sp)
$S \leq 16 \text{ mm}^2$	S
$16 \text{ mm}^2 < S \leq 35 \text{ mm}^2$	16 mm ²
$35 \text{ mm}^2 < S$	S/2

You must use a yellow/green cable as the PE conductor.

(7) Requirements on upstream protection device

Install upstream protection device on the input power circuit. The protection device must provide the protections on overcurrent, short-circuit and electricalsolation.

When selecting the protective device, you should consider the current capacity of the power cable, system overload capacity and short-circuit capacity of the upstream power distribution of the equipment. Generally, make selection according to the recommended values in section 8.4.

3.2.5 Description of Control Circuit Terminals

Terminal Arrangement of Control Circuit (0.75-7.5KW)

485+	485-	AI1	AI2	S1	S2	S3	S4	S5	T1A	T1B	T1C
+10V	A01	GND	+24V	OP	COM	DO1	FM	S6	T2A	T2B	T2C

Terminal Arrangement of Control Circuit (11-450KW)

485+	485-	AI1	AI2	GND	S1	S2	S3	S4	S5	S6	T1A	T1B	T1C
+10V	A01	A02	GND	+24V	OP	COM	COM	CME	DO1	FM	T2A	T2B	T2C

Description of Control Circuit Terminals

Table 3-3 Description of control circuit terminals

Type	Terminal	Name	Function Description
Power supply	+10V-GND	External +10V power supply	Provide +10 V power supply to external unit. Generally, it provides power supply to external potentiometer with resistance range of 1-5 kΩ. Maximum output current: 10 mA
	+24V-COM	External +24V power supply	Provide +24 V power supply to external unit. Generally, it provides power supply to DI/DO terminals and external sensors. Maximum output current: 200 mA
	OP	Input terminal of external power supply	Connect to +24 V by default. When DI1-DI5 need to be driven by external signal, OP needs to be connected to external power supply and be disconnected from +24 V.
Analog input	AI1-GND	Analog input 1	Input voltage range: 0-10 VDC Impedance: 22 kΩ
	AI2-GND	Analog input 2	Input range: 0-10 VDC/4-20 mA, decided by jumper J8 on the control board Impedance: 22 kΩ (voltage input), 500 Ω (current input)
Digital input	S1- OP	Digital input 1	Optical coupling isolation, compatible with dual polarity input Impedance: 2.4 kΩ Voltage range for level input: 9-30 V
	S2- OP	Digital input 2	
	S3- OP	Digital input 3	
	S4- OP	Digital input 4	
	S5- OP	High-speed pulse input	Besides features of DI1-DI4, it can be used for high-speed pulse input. Maximum input frequency: 100 kHz
Analog output	AO1-GND	Analog output 1	Voltage or current output decided by jumper J5. Output voltage range: 0-10 V Output current range: 0-20 mA
	AO2-GND	Analog output 2	Voltage or current output decided by jumper J12 Output voltage range: 0-10 V Output current range: 0-20 mA
Digital output Digital output	DO1-CME	Digital output 1	Optical coupling isolation, dual polarity open collector output Output voltage range: 0-24 V Output current range: 0-50 mA Note that CME and COM are internally insulated, but they are shorted by jumper J10 externally. In this case DO1 is driven by +24 V by default. If you want to drive DO1 by external power supply, remove the jumper J10.

Type	Terminal	Name	Function Description
	FM- COM	High-speed pulse output	It is limited by F5-00 (FM terminal output mode selection). As high-speed pulse output, the maximum frequency hits 100 kHz. As open-collector output, its specification is the same as that of DO1
Relay output	T/A-T/B	NC terminal	Contact driving capacity: 250 VAC, 3 A, COS ϕ = 0.4 30 VDC, 1 A Applying to Overvoltage Category II circuit
	T/A2-T/B2	NC terminal	
	T/A-T/C	NO terminal	
	T/A2-T/C2	NO terminal	
Communication	485+ 485-	Communication terminal	RS485 Communication terminal, Support Modbus communication protocol ,short 1,2 pins of J14 can match 100R terminal resistance

Chapter 4 Operation and display

4.1 Operation Panel

You can modify the parameters, monitor the working status and start or stop the H330 by operating the operation panel, as shown in the following figure.

Figure 4-1 Diagram of the operation panel

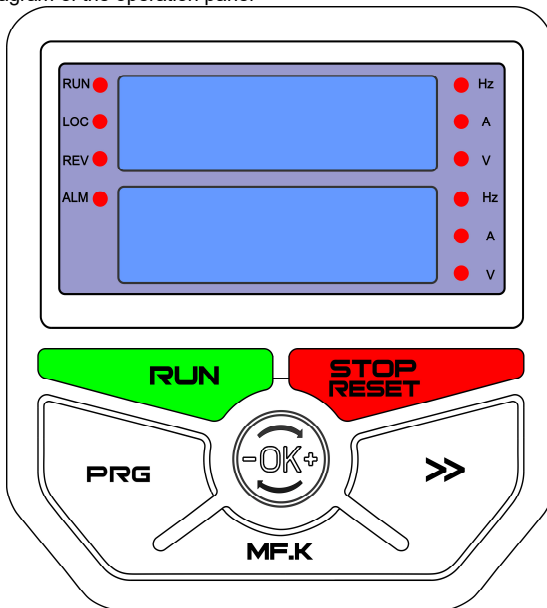

4.1.1 Description of Indicators

RUN: ON indicates that the AC drive is in the running state, and OFF indicates that the AC drive is in the stop state.

LOC: It indicates whether the AC drive is operated by means of operation panel, terminals or communication.

<input type="radio"/> LOCAL/REMOT: OFF	Operation panel control
<input checked="" type="radio"/> LOCAL/REMOT: ON	Terminal control
<input type="radio"/> LOCAL/REMOT: blinking	Communication control

REV: ON indicates reverse rotation, and OFF indicates forward rotation.

ALM: Fault indicator.

2) Unit Indicators:

Hz unit of frequency **A** unit of current **V** unit of voltage

3) Digital Display:

The 5-digit LED display is able to display the set frequency, output frequency, monitoring data and fault codes.

4.1.2 Description of Keys on the Operation Panel

Table 4-1 Description of keys on the operation panel

Key	Name	Function
PRGM	Programming	Enter or exit Level I menu
	Incremental encoder	Used to modify parameters.
>>	Shift	Select the displayed parameters in turn in the stop or running state, and select the digit to be modified when modifying parameters
RUN	RUN	Start the AC drive in the operation panel control mode
STOP /RESET	Stop/Reset	Stop the AC drive when it is in the running state and perform the reset operation when it is in the fault state. The functions of this key are restricted in F7-01
MF.K	Multifunction	Perform function switchover (such as quick switchover of command source or direction) according to the setting of F7-00

4.2 Viewing and Modifying Function Codes

The operation panel of the H330 adopts three-level menu.

The three-level menu consists of function code group (Level I), function code (Level II), and function code setting value (level III), as shown in the following figure.

Figure 4-2 Operation procedure on the operation panel

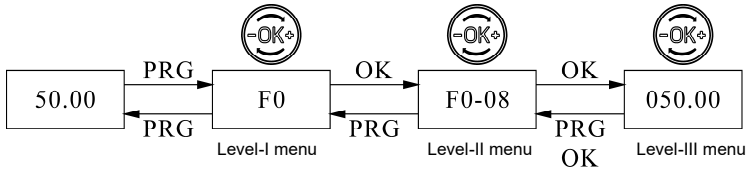

You can return to Level II menu from Level III menu by pressing PRG or ENTER.

After you press ENTER, the system saves the parameter setting first, and then goes back to Level II menu and shifts to the next function code.

After you press PRG, the system does not save the parameter setting, but directly returns to Level II menu and remains at the current function code.

Here is an example of changing the value of F3-02 to 15.00 Hz.

Figure 4-3 Example of changing the parameter value

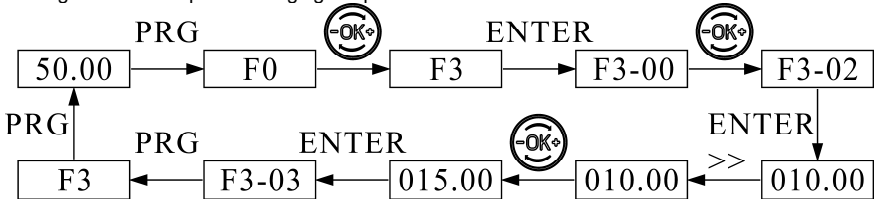

In Level III menu, if the parameter has no blinking digit, it means that the parameter cannot be modified. This may be because:

Such a function code is only readable, such as, AC drive model, actually detected parameter and running record parameter.

Such a function code cannot be modified in the running state and can only be changed at stop.

Chapter 5 Function Code Table

If FP-00 is set to a non-zero number, parameter protection is enabled. You must enter the correct user password to enter the menu.

To cancel the password protection function, enter with password and set FP-00 to 0.

Group F and Group A are standard function parameters. Group U includes the monitoring function parameters.

The symbols in the function code table are described as follows:

"☆": The parameter can be modified when the AC drive is in either stop or running state.

"★": The parameter cannot be modified when the AC drive is in the running state.

"●": The parameter is the actually measured value and cannot be modified.

"***": The parameter is factory parameter and can be set only by the manufacturer.

5.1 Standard Function Parameters

Function Code	Parameter Name	Setting Range	Default	Property
Group F0: Standard Function Parameters				
F0-00	Motor control mode	0: Sensorless flux vector control (SVC) 1: Voltage/Frequency (V/F) control	1	★
F0-01	Command source selection	0: Operation panel control (LED off) 1: Terminal control (LED on) 2: Communication control (LED blinking)	0	☆
F0-02	Main frequency source X selection	0: Digital setting (non-retentive at power failure) 1: Digital setting (retentive at power failure) 2: AI1 3: AI2 4: AI3 5: Pulse setting (S5) 6: Multi-reference 7: Simple PLC 8: PID 9: Communication setting	1	★
F0-03	Auxiliary frequency source Y selection	The same as F0-02 (Main frequency source X selection)	0	★
F0-04	Range of auxiliary frequency Y for X and Y operation	0: Relative to maximum frequency 1: Relative to main frequency X	0	☆
F0-05	Range of auxiliary frequency Y for X and Y operation	0%–150%	100%	☆
F0-06	Frequency source selection	Unit's digit (Frequency source selection) 0: Main frequency source X 1: X and Y operation (operation relationship determined by ten's digit) 2: Switchover between X and Y 3: Switchover between X and "X and Y operation" 4: Switchover between Y and "X and Y operation" Ten's digit (X and Y operation relationship) 0: X+Y 1: X-Y 2: Maximum 3: Minimum	00	☆
F0-07	Preset frequency	0.00 to maximum frequency (valid when frequency source is digital setting)	50.00Hz	☆
F0-08	Rotation direction	0: Same direction	0	☆

Function Code	Parameter Name	Setting Range	Default	Property
		1: Reverse direction		
F0-09	Maximum frequency	50.00Hz~320.00Hz (F0-22=2) 50.0Hz~1000.0Hz (F0-22=1)	50.00Hz	★
F0-10	Source of frequency upper limit	0: Set by F0-12 1: AI1 2: AI2 3: AI3 4: Pulse setting (DI5) 5: Communication setting	0	★
F0-11	Frequency upper limit	Frequency lower limit (F0-13 to maximum frequency (F0-09))	50.00Hz	☆
F0-12	Frequency upper limit offset	0.00 Hz to maximum frequency (F0-09)	0.00Hz	☆
F0-13	Frequency lower limit	0.00 Hz to frequency upper limit (F0-11)	0.00Hz	☆
F0-14	Running mode when set frequency lower than frequency lower limit	0: Run at frequency lower limit 1: Stop 2: Run at zero speed	0	☆
F0-15	Base frequency for UP/DOWN modification during running	0: Running frequency 1: Set frequency	0	★
F0-16	Retentive of digital setting frequency upon power failure	0: Not retentive 1: Retentive	0	☆
F0-17	Acceleration time 1	0.00~650.00s (F0-19 = 2) 0.0~6500.0s (F0-19 = 1) 0~65000s (F0-19 = 0)	Model dependent	☆
F0-18	Deceleration time 1	0.00~650.00s (F0-19 = 2) 0.0~6500.0s (F0-19 = 1) 0~65000s (F0-19 = 0)	Model dependent	☆
F0-19	Acceleration/Deceleration time unit	0: 1s 1: 0.1s 2: 0.01s	1	★
F0-20	Carrier frequency	0.5~16.0 kHz	Model dependent	☆
F0-21	Carrier frequency adjustment with temperature	0: No 1: Yes	1	☆
F0-22	Frequency reference resolution	1: 0.1 Hz 2: 0.01 Hz	2	★
Group F1: Start/Stop Control				
F1-00	Start mode	0: Direct start 1: Rotational speed tracking restart 2: Pre-excited start (asynchronous motor)	0	☆
F1-01	Rotational speed tracking mode	0: From frequency at stop 1: From power frequency 2: From maximum frequency	0	★
F1-02	Rotational speed tracking speed	1~100	20	☆
F1-03	Startup frequency	0.00~10.00 Hz	0.00Hz	☆
F1-04	Startup frequency holding time	0.0~100.0s	0.0s	★
F1-05	Startup DC braking current/ Pre-excited current	0%~100%	0%	★
F1-06	Startup DC braking time/ Pre-excited time	0.0~100.0s	0.0s	★
F1-07	Acceleration/Deceleration mode	0: Linear acceleration / deceleration 1: S-curve acceleration / deceleration A 2: S-curve acceleration / deceleration B	0	★
F1-08	Time proportion of S-curve start segment	0.0% to (100.0% - F1-09)	30.0%	★

Function Code	Parameter Name	Setting Range	Default	Property
F1-09	Time proportion of S-curve end segment	0.0% to (100.0% – F1-08)	30.0%	★
F1-10	Stop mode	0: Decelerate to stop 1: Coast to stop	0	☆
F1-11	Initial frequency of stop DC braking	0.00 Hz to maximum frequency	0.00Hz	☆
F1-12	Waiting time of stop DC braking	0.0–36.0s	0.0s	☆
F1-13	Stop DC braking current	0%–100%	0%	☆
F1-14	Stop DC braking time	0.0–36.0s	0.0s	☆
F1-15	Brake use ratio	0%–100%	100%	☆
F1-16	Brake Threshold Voltage	310.0V–800.0V	S: 368V T: 720V	☆
F2-00	G/P type selection	1: G type (constant torque load) 2: P type (variable torque load e.g. fan and pump)	Model dependent	★
F2-01	Motor type selection	0: Common asynchronous motor 1: Variable frequency asynchronous motor	0	★
F2-02	Rated motor power	0.1–1000.0 kW	Model dependent	★
F2-03	Rated motor voltage	1–2000 V	Model dependent	★
F2-04	Rated motor current	0.01–655.35 A (AC drive power ≤ 55 kW) 0.1–6553.5 A (AC drive power > 55 kW)	Model dependent	★
F2-05	Rated motor frequency	0.01 Hz to maximum frequency	Model dependent	★
F2-06	Rated motor rotational speed	1–65535 RPM	Model dependent	★
F2-07	Stator resistance (asynchronous motor)	0.001–65.535 Ω (AC drive power ≤ 55 kW) 0.0001–6.5535 Ω (AC drive power > 55 kW)	Model dependent	★
F2-08	Rotor resistance (asynchronous motor)	0.001–65.535 Ω (AC drive power ≤ 55 kW) 0.0001–6.5535 Ω (AC drive power > 55 kW)	Model dependent	★
F2-09	Leakage inductive reactance (asynchronous motor)	0.01–655.35 mH (AC drive power ≤ 55 kW) 0.001–65.535 mH (AC drive power > 55 kW)	Model dependent	★
F2-10	Mutual inductive reactance (asynchronous motor)	0.1–6553.5 mH (AC drive power ≤ 55 kW) 0.01–655.35 mH (AC drive power > 55 kW)	Model dependent	★
F2-11	No-load current (asynchronous motor)	0.01 to F2-04 (AC drive power ≤ 55 kW) 0.1 to F2-04 (AC drive power > 55 kW)	Model dependent	★
F2-12	Auto-tuning selection	0: No auto-tuning 1: Asynchronous motor static auto-tuning 2: Asynchronous motor complete auto-tuning 3: Asynchronous motor static complete auto-tuning	0	★
Group F3: Vector Control Parameters				
F3-00	Speed loop proportional gain 1	0–100	30	☆
F3-01	Speed loop integral time 1	0.01–10.00s	0.50s	☆
F3-02	Switchover frequency 1	0.00 to F3-05	5.00Hz	☆
F3-03	Speed loop proportional gain 2	0–100	20	☆
F3-04	Speed loop integral time 2	0.01–10.00s	1.00s	☆
F3-05	Switchover frequency 2	F3-02 to maximum output frequency	10.00Hz	☆
F3-06	Vector control slip gain	50%–200%	100%	☆
F3-07	Time constant of speed loop filter	0.000–0.100s	0.000s	☆

Function Code	Parameter Name	Setting Range	Default	Property
F3-08	Vector control over-excitation gain	0–200	64	☆
F3-09	Torque upper limit source in speed control mode	0: F3-10 1: AI1 2: AI2 3: Reserve 4: Pulse setting (S5) 5: Communication setting The full range of value 1-5 corresponds to the digital setting of F3-10	0	☆
F3-10	Digital setting of torque upper limit in speed control mode	0.0%–200.0%	150.0%	☆
F3-13	Excitation adjustment proportional gain	0–20000	2000	☆
F3-14	Excitation adjustment integral gain	0–20000	1300	☆
F3-15	Torque adjustment proportional gain	0–20000	2000	☆
F3-16	Torque adjustment integral gain	0–20000	1300	☆
F3-17	Speed loop integral property	Unit's digit: integral separation 0: Disabled 1: Enabled	0	☆
F3-18	Speed/Torque control selection	0: Speed control 1: Torque control	0	★
F3-19	Torque setting source in torque control	0: Digital setting (F3-21) 1: AI1 2: AI2 3: AI3 4: Pulse setting (S5) 5: Communication setting 6: MIN (AI1, AI2) 7: MAX (AI1, AI2) Full range of values 1–7 corresponds to the digital setting of F3-21.	0	★
F3-20	Reserved	-	-	●
F3-21	Torque digital setting in torque control	-200.0%–200.0%	150.0%	☆
F3-22	Reserved	-	-	●
F3-23	Forward maximum frequency in torque control	0.00 Hz to maximum frequency (F0-09)	50.00Hz	☆
F3-24	Reverse maximum frequency in torque control	0.00 Hz to maximum frequency (F0-09)	50.00Hz	☆
F3-25	Acceleration time in torque control	0.00–65000s	0.00s	☆
F3-26	Deceleration time in torque control	0.00–65000s	0.00s	☆
Group F4: V/F Control Parameters				
F4-00	V/F curve setting	0: Linear V/F 1: Multi-point V/F 2-9: Reserved 10: V/F complete separation 11: V/F half separation	0	★
F4-01	Torque boost	0.0% (No torque boost) 0.1%–30.0%	Model dependent	☆
F4-02	Cut-off frequency of torque boost	0.00 Hz to maximum output frequency	50.00Hz	★
F4-03	Multi-point V/F frequency 1 (F1)	0.00 Hz to F4-05	5.00Hz	★
F4-04	Multi-point V/F voltage 1 (V1)	0.0%–100.0%	20.0%	★
F4-05	Multi-point V/F frequency 2 (F2)	F4-03 to F4-07	25.00Hz	★

Function Code	Parameter Name	Setting Range	Default	Property
F4-06	Multi-point V/F voltage 2 (V2)	0.0%–100.0%	50.0%	★
F4-07	Multi-point V/F frequency 3 (F3)	F4-05 to rated motor frequency (F2-05)	50.00Hz	★
F4-08	Multi-point V/F voltage 3 (V3)	0.0%–100.0%	100.0%	★
F4-09	V/F slip compensation gain	0%–200.0%	0.0%	☆
F4-10	V/F over-excitation gain	0–200	64	☆
F4-11	V/F oscillation suppression gain	0–100	Model dependent	☆
F4-12	Voltage source for V/F separation	0: Digital setting (F4-13) 1: AI1 2: AI2 3: AI3 4: Pulse setting (S5) 5: Multi-reference 6: Simple PLC 7: PID 8: Communication setting 100.0% corresponds to the rated motor voltage (F2-03).	0	☆
F4-13	Voltage digital setting for V/F separation	0 V to rated motor voltage	0V	☆
F4-14	Voltage rise time of V/F separation	0.0–1000.0s It indicates the time for the voltage rising from 0 V to rated motor voltage.	0.0s	☆
F4-15	DPWM switchover frequency upper limit	0.00–15.00 Hz	12.00Hz	☆
F4-16	PWM modulation mode	0: Asynchronous modulation 1: Synchronous modulation	0	☆
F4-17	Random PWM depth	0: Random PWM invalid, 1–10	0	☆
Group F5: Input Terminals				
F5-00	S1 function selection	0: No function 1: Forward RUN (FWD) 2: Reverse RUN (REV) 3: Three-line control 4: Forward JOG (FJOG) 5: Reverse JOG (RJOG) 6: Terminal UP 7: Terminal DOWN	1	★
F5-01	S2 function selection	8: Coast to stop 9: Fault reset (RESET) 10: RUN pause 11: Normally open (NO) input of external fault	2	★
F5-02	S3 function selection	12: Multi-reference terminal 1 13: Multi-reference terminal 2 14: Multi-reference terminal 3 15: Multi-reference terminal 4 16: Terminal 1 for acceleration/ deceleration time selection 17: Terminal 2 for acceleration/ deceleration time selection	4	★
F5-03	S4 function selection	18: Frequency source switchover 19: UP and DOWN setting clear (terminal, operation panel) 20: Command source switchover terminal 1 21: Acceleration/Deceleration prohibited 22: PID pause 23: PLC status reset	9	★

Function Code	Parameter Name	Setting Range	Default	Property
F5-04	S5 function selection	24: Swing pause 25: Counter input 26: Counter reset 27: Length count input 28: Length reset 29: Torque control prohibited 30: Pulse input (enabled only for DI5) 31: Reserved	12	★
F5-05	S6 function selection	32: Immediate DC braking 33: Normally closed (NC) input of external fault 34: Frequency modification forbidden 35: Reverse PID action direction 36: External STOP terminal 1	13	★
F5-10	VDI1 function selection	37: Command source switchover terminal 2 38: PID integral pause 39: Switchover between main frequency source X and preset frequency	0	★
F5-11	VDI2 function selection	40: Switchover between auxiliary frequency source Y and preset frequency 41-42: Reserved	0	★
F5-12	VDI3 function selection	43: PID parameter switchover 44: User-defined fault 1 45: User-defined fault 2	0	★
F5-13	VDI4 function selection	46: Speed control/Torque control switchover 47: Emergency stop 48: External STOP terminal 2	0	★
F5-14	VDI5 function selection	49: Deceleration DC braking 50: Clear the current running time 51: Reserved 52: Reserved	0	★
F5-15	DI filter time	0.000s~1.000s	0.010s	☆
F5-16	Terminal command mode	0: Two-line mode 1 1: Two-line mode 2 2: Three-line mode 1 3: Three-line mode 2	0	★
F5-17	Terminal UP/DOWN rate	0.001Hz~65.535Hz	1.00Hz	☆
F5-18	DI1 delay time	0.0s~3600.0s	0.0s	★
F5-19	DI2 delay time	0.0s~3600.0s	0.0s	★
F5-20	DI3 delay time	0.0s~3600.0s	0.0s	★
F5-21	DI valid mode selection 1	0: High level 1: low level Unit's digit (S1 valid mode) Ten's digit (S2 valid mode) Hundred's digit (S3 valid state) Thousand's digit (S4 valid mode) Ten thousand's digit (S5 valid mode)	00000	★
F5-22	DI valid mode selection 2	0: High level 1: low level Unit's digit (S6 valid mode) Ten's digit (S7 valid mode) Hundred's digit (S8 state) Thousand's digit (S9 valid mode) Ten thousand's digit (S10 valid mode)	00000	★
F5-23	VDI state setting mode	0: Decided by state of VDOx 1: Decided by F5-24 Unit's digit (VDI1) Ten's digit (VDI2) Hundred's digit (VDI3) Thousand's digit (VDI4) Ten thousand's digit (VDI5)	00000	★

Function Code	Parameter Name	Setting Range	Default	Property
F5-24	VDI state selection	0: Invalid; 1: Valid Unit's digit (VDI1) Ten's digit (VDI2) Hundred's digit (VDI3) Thousand's digit (VDI4) Ten thousand's digit (VDI5)	00000	★
F5-25	AI curve 1 minimum input	0.00V~F5-27	0.00V	☆
F5-26	Corresponding setting of AI curve 1 minimum input	-100.0%~+100.0%	0.0%	☆
F5-27	AI curve 1 maximum input	F5-25~+10.00V	10.00V	☆
F5-28	Corresponding setting of AI curve 1 maximum input	-100.0%~+100.0%	100.0%	☆
F5-29	AI1 filter time	0.00s~10.00s	0.10s	☆
F5-30	AI curve 2 minimum input	0.00V~F5-32	2.00V	☆
F5-31	Corresponding setting of AI curve 2 minimum input	-100.0%~+100.0%	0.0%	☆
F5-32	AI curve 2 maximum input	F5-30~+10.00V	10.00V	☆
F5-33	Corresponding setting of AI curve 2 maximum input	-100.0%~+100.0%	100.0%	☆
F5-34	AI2 filter time	0.00s~10.00s	0.10s	☆
F5-39	Operation panel potentiometer(AI3) filter time	0.00s~10.00s	0.10s	☆
F5-40	Pulse minimum input	0.00kHz~F5-42	0.00kHz	☆
F5-41	Corresponding setting of pulse minimum input	-100.0%~100.0%	0.0%	☆
F5-42	Pulse maximum input	F5-40~100.00kHz	50.00kHz	☆
F5-43	Corresponding setting of pulse maximum input	-100.0%~100.0%	100.0%	☆
F5-44	Pulse filter time	0.00s~10.00s	0.10s	☆
F5-45	Setting for AI less than minimum input	Unit's digit (Setting for AI1 less than minimum input) 0: Minimum value 1: 0.0% Ten's digit (Setting for AI2 less than minimum input)	00	☆
Group F6: Output Terminals				
F6-00	FM terminal output mode	0: Pulse output (FMP) 1: Switch signal output (FMR)	0	☆
F6-01	FMR function (open-collector output terminal)	0: No output 1: AC drive running 2: Fault output (stop) 3: Frequency-level detection FDT1 output 4: Frequency reached 5: Zero-speed running (no output at stop) 6: Motor overload pre-warning 7: AC drive overload pre-warning 8: Set count value reached 9: Designated count value reached 10: Length reached	0	☆

Function Code	Parameter Name	Setting Range	Default	Property
F6-02	Relay function (T/A-T/B-T/C)	11: PLC cycle complete 12: Accumulative running time reached 13: Frequency limited 14: Torque limited 15: Ready for RUN 16: AI1 larger than AI2 17: Frequency upper limit reached 18: Frequency lower limit reached (no output at stop) 19: Undervoltage state output 20: Communication setting 21: Reserved	2	☆
F6-03	Relay function (T/A2-T/B2-T/C2)	22: Reserved 23: Zero-speed running 2 (having output at stop) 24: Accumulative power-on time reached 25: Frequency level detection FDT2 output 26: Frequency 1 reached 27: Frequency 2 reached 28: Current 1 reached 29: Current 2 reached 30: Timing reached 31: AI1 input limit exceeded 32: Load becoming 0	0	☆
F6-04	DO1 function selection (open-collector output terminal)	33: Reverse running 34: Zero current state 35: Module temperature reached 36: Software current limit exceeded 37: Frequency lower limit reached (having output at stop) 38: Alarm output 39: Motor overheat warning 40: Current running time reached 41:Reserved 42:Reserved	1	☆
F6-05	Reserved		0	☆
F6-06	VDO1 function selection	0: Short with physical DIx internally 1–40: Refer to function selection of physical DO in group F6.	0	☆
F6-07	VDO2 function selection	0: Short with physical DIx internally 1–40: Refer to function selection of physical DO in group F6.	0	☆
F6-08	VDO3 function selection	0: Short with physical DIx internally 1–40: Refer to function selection of physical DO in group F6.	0	☆
F6-09	VDO4 function selection	0: Short with physical DIx internally 1–40: Refer to function selection of physical DO in group F5.	0	☆
F6-10	VDO5 function selection	0: Short with physical DIx internally 1–40: Refer to function selection of physical DO in group F6.	0	☆
F6-11	FMR output delay time	0.0–3600.0s	0.0s	☆
F6-12	Relay 1 output delay time	0.0–3600.0s	0.0s	☆
F6-13	Relay 2 output delay time	0.0–3600.0s	0.0s	☆
F6-14	DO1 output delay time	0.0–3600.0s	0.0s	☆
F6-15	Reserved			☆
F6-16	VDO1 output delay	0.0–3600.0s	0.0s	☆
F6-17	VDO2 output delay	0.0–3600.0s	0.0s	☆
F6-18	VDO3 output delay	0.0–3600.0s	0.0s	☆
F6-19	VDO4 output delay	0.0–3600.0s	0.0s	☆
F6-20	VDO5 output delay	0.0–3600.0s	0.0s	☆

Function Code	Parameter Name	Setting Range	Default	Property
F6-21	DO valid mode selection	0- Positive logic; 1- Negative logic Unit's digit (FMR valid mode) Ten's digit (Relay 1 valid mode) Hundred's digit (Relay 2 valid mode) Thousand's digit (DO1 valid mode) Ten thousand's digit (DO2 valid mode)	00000	☆
F6-22	VDO valid mode selection	0- Positive logic; 1- Negative logic Unit's digit (VDO1 valid mode) Ten's digit (VDO2 valid mode) Hundred's digit (VDO3 valid mode) Thousand's digit (VDO4 valid mode) Ten thousand's digit (VDO5 valid mode)	00000	☆
F6-23	FMP function selection	0: Running frequency 1: Set frequency 2: Output current 3: Output torque (absolute value) 4: Output power 5: Output voltage	0	☆
F6-24	AO1 function selection	6: Pulse input 7: AI1 8: AI2 9: AI3 10: Length	0	☆
F6-25	AO2 function selection	11: Count value 12: Communication setting 13: Motor rotational speed 14: Output current 15: Output voltage 16: Output torque (actual value)	1	☆
F6-26	Maximum FMP output frequency	0.01~100.00 kHz	50.00kHz	☆
F6-27	AO1 offset coefficient	-100.0%~100.0%	0.0%	☆
F6-28	AO1 gain	-10.00~10.00	1.00	☆
F6-29	AO2 offset coefficient	-100.0%~100.0%	0.0%	☆
F6-30	AO2 gain	-10.00~10.00	1.00	☆
Group F7: Operation Panel and Display				
F7-00	MF.K Key function selection	0: MF.K key disabled 1: Switchover between operation panel control and remote command control (terminal or communication) 2: Switchover between forward rotation and reverse rotation 3: Forward JOG 4: Reverse JOG	0	★
F7-01	STOP/RESET key function	0: STOP/RESET key enabled only in operation panel control 1: STOP/RESET key enabled in any operation mode	1	☆
F7-02	LED display running parameters 1	0000~FFFF Bit00: Running frequency 1 (Hz) Bit01: Set frequency (Hz) Bit02: Bus voltage (V) Bit03: Output voltage (V) Bit04: Output current (A) Bit05: Output power (kW) Bit06: Output torque (%) Bit07: DI input status Bit08: DO output status Bit09: AI1 voltage (V) Bit10: AI2 voltage (V) Bit11: AI3 voltage (V) Bit12: Count value Bit13: Length value	1D	☆

Function Code	Parameter Name	Setting Range	Default	Property
		Bit14: Load speed display Bit15: PID setting		
F7-03	LED display running parameters 2	0000~FFFF Bit00: PID feedback Bit01: PLC stage Bit02: Pulse setting frequency (kHz) Bit03: Running frequency 2 (Hz) Bit04: Remaining running time Bit05: AI1 voltage before correction (V) Bit06: AI2 voltage before correction (V) Bit07: AI3 voltage before correction (V) Bit08: Linear speed Bit09: Current power-on time (Hour) Bit10: Current running time (Min) Bit11: Pulse setting frequency (Hz) Bit12: Communication setting value Bit13: Encoder feedback speed (Hz) Bit14: Main frequency X display (Hz) Bit15: Auxiliary frequency Y display (Hz)	0	☆
F7-04	LED display stop parameters	0000~FFFF Bit00: Set frequency (Hz) Bit01: Bus voltage (V) Bit02: DI input status Bit03: DO output status Bit04: AI1 voltage (V) Bit05: AI2 voltage (V) Bit06: AI3 voltage (V) Bit07: Count value Bit08: Length value Bit09: PLC stage Bit10: Load speed Bit11: PID setting Bit12: Pulse setting frequency (kHz)	33	☆
F7-05	Heatsink temperature of inverter module	0.0~100.0°C	-	●
F7-06	Load speed display coefficient	0.0001~6.5000	3.0000	☆
F7-07	Number of decimal places for load speed display	0: 0 decimal place 1: 1 decimal place 2: 2 decimal places 3: 3 decimal places	1	☆
F7-08	Accumulative running time	0~65535 h	-	●
F7-09	Accumulative power-on time	0~65535 h	-	●
F7-10	Accumulative power consumption	0~65535 kWh	-	●
F7-11	Product number	-	-	●
F7-12	Software version	-	-	●
F7-14	LED2 display parameters	00: Running frequency (Hz) 01: Set frequency (Hz) 02: Bus voltage 03: Output voltage 04: Output current 05: Output power 06: Output torque 07: DI state 08: DO state 09: AI1 voltage (V) 10: AI2 voltage (V)	4	☆

Function Code	Parameter Name	Setting Range	Default	Property
		11: AI3 voltage (V) 12: Count value 13: Length value 14: Load speed 15: PID setting 16: PID feedback 17: PLC stage 18: Input pulse frequency (Hz) 19: Feedback speed (Hz) 20: Remaining running time 21: AI1 voltage before correction 22: AI2 voltage before correction 24: Linear speed 25: Accumulative power-on time 26: Accumulative running time 27: Pulse input frequency 28: Communication setting value 29: Encoder feedback speed 30: Main frequency X 31: Auxiliary frequency Y		
Group F8: Auxiliary Functions				
F8-00	JOG running frequency	0.00 Hz to maximum frequency	2.00Hz	☆
F8-01	JOG acceleration time	0.0–6500.0s	20.0s	☆
F8-02	JOG deceleration time	0.0–6500.0s	20.0s	☆
F8-03	Acceleration time 2	0.0–6500.0s	Model dependent	☆
F8-04	Deceleration time 2	0.0–6500.0s	Model dependent	☆
F8-05	Acceleration time 3	0.0–6500.0s	Model dependent	☆
F8-06	Deceleration time 3	0.0–6500.0s	Model dependent	☆
F8-07	Acceleration time 4	0.0–500.0s	Model dependent	☆
F8-08	Deceleration time 4	0.0–6500.0s	Model dependent	☆
F8-09	Jump frequency 1	0.00 Hz to maximum frequency	0.00Hz	☆
F8-10	Jump frequency 2	0.00 Hz to maximum frequency	0.00Hz	☆
F8-11	Frequency jump amplitude	0.00 Hz to maximum frequency	0.00Hz	☆
F8-12	Forward/Reverse rotation dead-zone time	0.0–3000.0s	0.0s	☆
F8-13	Reverse control	0: Enabled 1: Disabled	0	☆
F8-14	Cooling fan control	0: Fan working during running 1: Fan working continuously	0	☆
F8-15	Droop control	0.00–10.00 Hz	0.00Hz	☆
F8-16	Accumulative power-on time threshold	0–65000 h	0h	☆
F8-17	Accumulative running time threshold	0–65000 h	0h	☆
F8-18	Startup protection	0: No 1: Yes	0	☆
F8-19	Frequency detection value (FDT1)	0.00 Hz to maximum frequency	50.00Hz	☆
F8-20	Frequency detection hysteresis (FDT hysteresis 1)	0.0%–100.0% (FDT1 level)	5.0%	☆
F8-21	Detection range of frequency reached	0.00–100% (maximum frequency)	0.0%	☆
F8-22	Jump frequency during acceleration/	0: Disabled1: Enabled	0	☆

Function Code	Parameter Name	Setting Range	Default	Property
	deceleration			
F8-25	Frequency switchover point between acceleration time 1 and acceleration time 2	0.00 Hz to maximum frequency	0.00Hz	☆
F8-26	Frequency switchover point between deceleration time 1 and deceleration time 2	0.00 to maximum frequency	0.00Hz	☆
F8-27	Terminal JOG preferred	0: Disabled 1: Enabled	0	☆
F8-28	Frequency detection value (FDT2)	0.00 to maximum frequency	50.00Hz	☆
F8-29	Frequency detection hysteresis (FDT hysteresis 2)	0.0%–100.0% (FDT2 level)	5.0%	☆
F8-30	Any frequency reaching detection value 1	0.00 Hz to maximum frequency	50.00Hz	☆
F8-31	Any frequency reaching detection amplitude 1	0.0%–100.0% (maximum frequency)	0.0%	☆
F8-32	Any frequency reaching detection value 2	0.00 Hz to maximum frequency	50.00Hz	☆
F8-33	Any frequency reaching detection amplitude 2	0.0%–100.0% (maximum frequency)	0.0%	☆
F8-34	Zero current detection level	0.0%–300.0% (rated motor current)	5.0%	☆
F8-35	Zero current detection delay time	0.00–600.00s	0.10s	☆
F8-36	Output overcurrent threshold	0.0% (no detection) 0.1%–300.0% (rated motor current)	200.0%	☆
F8-37	Output overcurrent detection delay time	0.00–600.00s	0.00s	☆
F8-38	Any current reaching 1	0.0%–300.0% (rated motor current)	100.0%	☆
F8-39	Any current reaching 1 amplitude	0.0%–300.0% (rated motor current)	0.0%	☆
F8-40	Any current reaching 2	0.0%–300.0% (rated motor current)	100.0%	☆
F8-41	Any current reaching 2 amplitude	0.0%–300.0% (rated motor current)	0.0%	☆
F8-42	Timing function	0: Disabled 1: Enabled	0	☆
F8-43	Timing duration source	0: F8-44 1: A11 2: A12 3: A13 (100% of analog input corresponds to the value of F8-44)	0	☆
F8-44	Timing duration	0.0–6500.0 min	0.0Min	☆
F8-45	A11 input voltage lower limit	0.00 V to F8-46	3.10V	☆
F8-46	A11 input voltage upper limit	F8-45 to 10.00 V	6.80V	☆
F8-47	Module temperature threshold	0°C~100°C	75°C	☆
F8-48	Current running time reached	0.0Min~6500.0Min	0.0Min	☆
Group F9: Process Control PID Function				
F9-00	PID setting source	0: FA-01 1: A11 2: A12 3: A13 4: Pulse setting (DI5) 5: Communication setting 6: Multi-reference	0	☆
F9-01	PID digital setting	0.0%–100.0%	50.0%	☆

Function Code	Parameter Name	Setting Range	Default	Property
F9-02	PID feedback source	0: AI1 1: AI2 2: AI3 3: AI1 – AI2 4: Pulse setting (DI5) 5: Communication setting 6: AI1 + AI2 7: MAX (AI1 , AI2) 8: MIN (AI1 , AI2)	0	☆
F9-03	PID action direction	0: Forward action 1: Reverse action	0	☆
F9-04	PID setting feedback range	0–65535	1000	☆
F9-05	Proportional gain Kp1	0.0–100.0	20.0	☆
F9-06	Integral time Ti1	0.01–10.00s	2.00s	☆
F9-07	Differential time Td1	0.00–10.000	0.000s	☆
F9-08	Cut-off frequency of PID reverse rotation	0.00 to maximum frequency	0.00Hz	☆
F9-09	PID deviation limit	0.0%–100.0%	0.0%	☆
F9-10	PID differential limit	0.00%–100.00%	0.10%	☆
F9-11	PID setting change time	0.00–650.00s	0.00s	☆
F9-12	PID feedback filter time	0.00–60.00s	0.00s	☆
F9-13	PID output filter time	0.00–60.00s	0.00s	☆
F9-14	Proportional gain Kp2	0.0–100.0	20.0	☆
F9-15	Integral time Ti2	0.01–10.00s	2.00s	☆
F9-16	Differential time Td2	0.000–10.000s	0.000s	☆
F9-17	PID parameter switchover condition	0: No switchover 1: Switchover via DI 2: Automatic switchover based on deviation	0	☆
F9-18	PID parameter switchover deviation 1	0.0% to F9-19	20.0%	☆
F9-19	PID parameter switchover deviation 2	F9-18 to 100.0%	80.0%	☆
F9-20	PID initial value	0.0%–100.0%	0.0%	☆
F9-21	PID initial value holding time	0.00–650.00s	0.00s	☆
F9-22	Maximum deviation between two PID outputs in forward direction	0.00%–100.00%	1.00%	☆
F9-23	Maximum deviation between two PID outputs in reverse direction	0.00%–100.00%	1.00%	☆
F9-24	PID integral property	Unit's digit (Integral separated) 0: Invalid 1: Valid Ten's digit (Whether to stop integral operation when the output reaches the limit) 0: Continue integral operation 1: Stop integral operation	00	☆
F9-25	Detection value of PID feedback loss	0.0%: Not judging feedback loss 0.1%–100.0%	0.0%	☆
F9-26	Detection time of PID feedback loss	0.0–20.0s	0.0s	☆
F9-27	PID operation at stop	0: No PID operation at stop 1: PID operation at stop	0	☆
F9-28	PID sleep mode	0: No sleep 1: sleep use frequency mode 2: sleep use PID error mode	2	☆
F9-29	Deviation value of PID feedback when sleep	0.0%–F9-32 (The full range corresponds to the PID setting)	5.0%	
F9-30	Dormant frequency	0.00 Hz to max frequency	20.00Hz	☆

Function Code	Parameter Name	Setting Range	Default	Property
F9-31	Dormant delay time	0.0–6500.0s	10.0s	☆
F9-32	Deviation value of PID feedback when wake up	F9-29–100.0% (The full range corresponds to the PID setting)	20.0%	☆
F9-33	Wakeup delay time	0.0–6500.0s	3.0s	☆
F9-34	Sleep rate	1–10 (use when PID sleep use PID error mode)	1	☆
Group FA: Fault and Protection				
FA-00	Motor overload protection selection	0: Disabled 1: Enabled	1	☆
FA-01	Motor overload protection gain	0.20–10.00	1.00	☆
FA-02	Motor overload warning coefficient	50%–100%	80%	☆
FA-03	Overvoltage stall gain	0 (no stall overvoltage)–100	40	☆
FA-04	Overvoltage stall protective voltage	120%–150%	S: 380V T: 760V	☆
FA-05	Overcurrent stall gain	0–100	20	☆
FA-06	Overcurrent stall protective current	100%–200%	150%	☆
FA-07	Short-circuit to ground upon power-on	0: Disabled 1: Enabled	1	☆
FA-08	Rapid current limit	0: Disabled 1: Enabled	1	☆
FA-09	Fault auto reset times	0–20	0	☆
FA-10	DO action during fault auto reset	0: Not act 1: Act	0	☆
FA-11	Time interval of fault auto reset	0.1s–100.0s	1.0s	☆
FA-12	Input phase loss protection/ contactor energizing protection selection	Unit's digit: Input phase loss protection Ten's digit: Contactor energizing protection 0: Disabled 1: Enabled	11	☆
FA-13	Output phase loss protection selection	0: Disabled 1: Enabled	1	☆
FA-16	Fault protection action selection 1	Unit's digit (Motor overload, Err11) 0: Coast to stop 1: Stop according to stop mode 2: Continue to run Ten's digit (Power input phase loss, Err12) Hundred's digit (Power output phase loss, Err13) Thousand's digit (External equipment fault, Err15) Ten thousand's digit (Communication fault, Err16)	00000	☆
FA-17	Fault protection action selection 2	Unit's digit (Reserved) 0: Coast to stop 1: Stop according to the stop mode Ten's digit (EEPROM read-write fault, Err21) 0: Coast to stop 1: Stop according to the stop mode Hundred's digit (Reserved) Thousand's digit (Motor overheat, Err25) Ten thousand's digit (Accumulative running time reached, Err26)	00000	☆
FA-18	Fault protection action selection 3	Unit's digit (User-defined fault 1, Err27) 0: Coast to stop 1: Stop according to stop mode 2: Continue to run Ten's digit (User-defined fault 2, Err28) 0: Coast to stop 1: Stop according to stop mode	00000	☆

Function Code	Parameter Name	Setting Range	Default	Property
		2: Continue to run Hundred's digit (Accumulative power-on time reached, Err29) 0: Coast to stop 1: Stop according to stop mode 2: Continue to run Thousand's digit (Load becoming 0, Err30) 0: Coast to stop 1: Stop according to the stop mode 2: Continue to run at 7% of rated motor frequency and resume to the set frequency if the load recovers Ten thousand's digit (PID feedback lost during running, Err31) 0: Coast to stop 1: Stop according to stop mode 2: Continue to run		
FA-21	Frequency selection for continuing to run upon fault	0: Current running frequency 1: Set frequency 2: Frequency upper limit 3: Frequency lower limit 4: Backup frequency upon abnormality	0	☆
FA-22	Backup frequency upon abnormality	0.0%–100.0% (maximum frequency)	100.0%	☆
FA-23	Action selection at instantaneous power failure	0: Invalid 1: Decelerate 2: Decelerate to stop	0	☆
FA-24	Action pause judging voltage at instantaneous power failure	80.0%–100.0%	90.0%	☆
FA-25	Voltage rally judging time at instantaneous power failure	0.00–100.00s	0.50s	☆
FA-26	Action judging voltage at instantaneous power failure	60.0%–100.0% (standard bus voltage)	80.0%	☆
FA-27	Protection upon load becoming 0	0: Disabled 1: Enabled	0	☆
FA-28	Detection level of load becoming 0	0.0%–100.0% (rated motor current)	10.0%	☆
FA-29	Detection time of load becoming 0	0.0–60.0s	1.0s	☆
FA-33	Detection value of too large speed deviation	0.0%–50.0% (maximum frequency)	20.0%	☆
FA-34	Detection time of too large speed deviation	0.0–60.0s	5.0s	☆
Group FB: Swing Frequency, Fixed Length and Count				
Fb-00	Swing frequency setting mode	0: Relative to the central frequency 1: Relative to the maximum frequency	0	☆
Fb-01	Swing frequency amplitude	0.0%–100.0%	0.0%	☆
Fb-02	Jump frequency amplitude	0.0%–50.0%	0.0%	☆
Fb-03	Swing frequency cycle	0.0–3000.0s	10.0s	☆
Fb-04	Triangular wave rising time coefficient	0.0%–100.0%	50.0%	☆
Fb-05	Set length	0–65535 m	1000m	☆
Fb-06	Actual length	0–65535 m	0m	☆
Fb-07	Number of pulses per meter	0.1–6553.5	100.0	☆
Fb-08	Set count value	1–65535	1000	☆
Fb-09	Designated count value	1–65535	1000	☆

Function Code	Parameter Name	Setting Range	Default	Property
Group FC: Communication Parameters				
FC-00	Local address	0: Broadcast address, 1-247	1	☆
FC-01	Baud rate	0: 300BPS 1: 600BPS 2: 1200BPS 3: 2400BPS 4: 4800BPS 5: 9600BPS 6: 19200BPS 7: 38400BPS 8: 57600BPS 9: 115200BPS	5	☆
FC-02	Data format	0: No check, data format <8,N,2> 1: Even parity check, data format <8,E,1> 2: Odd Parity check, data format <8,O,1> 3: No check, data format <8,N,1> Valid for Modbus	0	☆
FC-03	Response delay	0ms~20ms	2	☆
FC-04	Communication timeout	0.0s (invalid) 0.1-60.0s	0.0	☆
FC-05	Modbus protocol selection	Unit's digit: Modbus protocol 0: Non-standard Modbus protocol 1: Standard Modbus protocol	0	☆
FC-06	Communication reading current resolution	0: 0.01A 1: 0.1A	0	☆
Group FD: Multi-Reference and Simple PLC Function				
Fd-00	Reference 0	-100.0%~100.0%	0.0%	☆
Fd-01	Reference 1	-100.0%~100.0%	0.0%	☆
Fd-02	Reference 2	-100.0%~100.0%	0.0%	☆
Fd-03	Reference 3	-100.0%~100.0%	0.0%	☆
Fd-04	Reference 4	-100.0%~100.0%	0.0%	☆
Fd-05	Reference 5	-100.0%~100.0%	0.0%	☆
Fd-06	Reference 6	-100.0%~100.0%	0.0%	☆
Fd-07	Reference 7	-100.0%~100.0%	0.0%	☆
Fd-08	Reference 8	-100.0%~100.0%	0.0%	☆
Fd-09	Reference 9	-100.0%~100.0%	0.0%	☆
Fd-10	Reference 10	-100.0%~100.0%	0.0%	☆
Fd-11	Reference 11	-100.0%~100.0%	0.0%	☆
Fd-12	Reference 12	-100.0%~100.0%	0.0%	☆
Fd-13	Reference 13	-100.0%~100.0%	0.0%	☆
Fd-14	Reference 14	-100.0%~100.0%	0.0%	☆
Fd-15	Reference 15	-100.0%~100.0%	0.0%	☆
Fd-16	Simple PLC running mode	0: Stop after the AC drive runs one cycle 1: Keep final values after the AC drive runs one cycle 2: Repeat after the AC drive runs one cycle	0	☆
Fd-17	Simple PLC retentive selection	Unit's digit (Retentive upon power failure) 0: No 1: Yes Ten's digit (Retentive upon stop) 0: No 1: Yes	00	☆
Fd-18	Running time of simple PLC reference 0	0.0s(h)~6553.5s(h)	0.0s(h)	☆
Fd-19	Acceleration/deceleration time of simple PLC reference 0	0~3	0	☆
Fd-20	Running time of simple PLC reference 1	0.0s(h)~6553.5s(h)	0.0s(h)	☆
Fd-21	Acceleration/deceleration time of simple PLC	0~3	0	☆

Function Code	Parameter Name	Setting Range	Default	Property
	reference 1			
Fd-22	Running time of simple PLC reference 2	0.0s(h)~6553.5s(h)	0.0s(h)	☆
Fd-23	Acceleration/deceleration time of simple PLC reference 2	0~3	0	☆
Fd-24	Running time of simple PLC reference 3	0.0s(h)~6553.5s(h)	0.0s(h)	☆
Fd-25	Acceleration/deceleration time of simple PLC reference 3	0~3	0	☆
Fd-26	Running time of simple PLC reference 4	0.0s(h)~6553.5s(h)	0.0s(h)	☆
Fd-27	Acceleration/deceleration time of simple PLC reference 4	0~3	0	☆
Fd-28	Running time of simple PLC reference 5	0.0s(h)~6553.5s(h)	0.0s(h)	☆
Fd-29	Acceleration/deceleration time of simple PLC reference 5	0~3	0	☆
Fd-30	Running time of simple PLC reference 6	0.0s(h)~6553.5s(h)	0.0s(h)	☆
Fd-31	Acceleration/deceleration time of simple PLC reference 6	0~3	0	☆
Fd-32	Running time of simple PLC reference 7	0.0s(h)~6553.5s(h)	0.0s(h)	☆
Fd-33	Acceleration/deceleration time of simple PLC reference 7	0~3	0	☆
Fd-34	Running time of simple PLC reference 8	0.0s(h)~6553.5s(h)	0.0s(h)	☆
Fd-35	Acceleration/deceleration time of simple PLC reference 8	0~3	0	☆
Fd-36	Running time of simple PLC reference 9	0.0s(h)~6553.5s(h)	0.0s(h)	☆
Fd-37	Acceleration/deceleration time of simple PLC reference 9	0~3	0	☆
Fd-38	Running time of simple PLC reference 10	0.0s(h)~6553.5s(h)	0.0s(h)	☆
Fd-39	Acceleration/deceleration time of simple PLC reference 10	0~3	0	☆
Fd-40	Running time of simple PLC reference 11	0.0s(h)~6553.5s(h)	0.0s(h)	☆
Fd-41	Acceleration/deceleration time of simple PLC reference 11	0~3	0	☆
Fd-42	Running time of simple PLC reference 12	0.0s(h)~6553.5s(h)	0.0s(h)	☆
Fd-43	Acceleration/deceleration time of simple PLC reference 12	0~3	0	☆
Fd-44	Running time of simple PLC reference 13	0.0s(h)~6553.5s(h)	0.0s(h)	☆
Fd-45	Acceleration/deceleration time of simple PLC reference 13	0~3	0	☆
Fd-46	Running time of simple PLC reference 14	0.0s(h)~6553.5s(h)	0.0s(h)	☆
Fd-47	Acceleration/deceleration time of simple PLC reference 14	0~3	0	☆

Function Code	Parameter Name	Setting Range	Default	Property
	on time of simple PLC reference 14			
Fd-48	Running time of simple PLC reference 15	0.0–6553.5s (h)	0.0s(h)	☆
Fd-49	Acceleration/deceleration time of simple PLC reference 15	0–3	0	☆
Fd-50	Time unit of simple PLC running	0: s (second)1:h (hour)	0	☆
Fd-51	Reference 0 source	0: Set by FC-00 1: AI1 2: AI2 3: AI3 4: Pulse setting 5: PID 6: Set by preset frequency (F0- 08), modified via terminal UP/ DOWN	0	☆
Group FE: Error record				
FE-00	1st fault type	0: No fault 1: Reserved 2: Overcurrent during acceleration 3: Overcurrent during deceleration 4: Overcurrent at constant speed 5: Overvoltage during acceleration 6: Overvoltage during deceleration 7: Overvoltage at constant speed 8: Buffer resistance overload 9: Undervoltage 10: AC drive overload	—	●
FE-01	2nd fault type	11: Motor overload 12: Power input phase loss 13: Power output phase loss 14: Module overheat 15: External equipment fault 16: Communication fault 17: Contactor fault 18: Current detection fault 19: Motor auto-tuning fault 19: Motor auto-tuning fault 20: Encoder/PG card fault	—	●
FE-02	3rd (latest) fault type	21: EEPROM read-write fault 22: AC drive hardware fault 23: Short circuit to ground 24: Reserved 25: Reserved 26: Accumulative running time reached 27: User-defined fault 1 28: User-defined fault 2 29: Accumulative power-on time reached 30: Load becoming 0 31: PID feedback lost during running 40: With-wave current limit fault 41: Motor switchover fault during running 42: Too large speed deviation 99: Communication fault between Keypad and control board (ERR99)	—	●
FE-03	Frequency upon 3rd fault	—	—	●
FE-04	Current upon 3rd fault	—	—	●
FE-05	Bus voltage upon 3rd fault	—	—	●
FE-06	DI status upon 3rd fault	—	—	●
FE-07	Output terminal status upon 3rd fault	—	—	●
FE-08	AC drive status upon 3rd fault	—	—	●

Function Code	Parameter Name	Setting Range	Default	Property
FE-09	Power-on time upon 3rd fault	—	—	●
FE-10	Running time upon 3rd fault	—	—	●
FE-11	Frequency upon 2nd fault	—	—	●
FE-12	Current upon 2nd fault	—	—	●
FE-13	Bus voltage upon 2nd fault	—	—	●
FE-14	DI status upon 2nd fault	—	—	●
FE-15	Output terminal status upon 2nd fault	—	—	●
FE-16	AC drive status upon 2rd fault	—	—	●
FE-17	Power-on time upon 2rd fault	—	—	●
FE-18	Running time upon 2rd fault	—	—	●
FE-19	Frequency upon 1st fault	—	—	●
FE-20	Current upon 1st fault	—	—	●
FE-21	Bus voltage upon 1rd fault	—	—	●
FE-22	DI status upon 1st fault	—	—	●
FE-23	Output terminal status upon 1st fault	—	—	●
FE-24	AC drive status upon 1rd fault	—	—	●
FE-25	Power-on time upon 1rd fault	—	—	●
FE-26	Running time upon 1rd fault	—	—	●
Group FP: Function Code Management				
FP-00	User password	0~65535	0	☆
FP-01	Restore default settings	0: No operation 01: Restore factory settings except motor parameters 02: Clear records	0	★
FP-02	Parameter modification property	0: Modifiable 1: Not modifiable	0	☆
FP-05	Copy parameters	0: No operation 1: Upload Parameters 2: Download Parameters (Include Motor Parameters) 3: Download Parameters (Exclude Motor Parameters)	0	★

5.2 Monitoring Parameters

Function Code	Parameter Name	Min. Unit	Communication Address
Group U0: Standard Monitoring Parameters			
U0-00	Running frequency (Hz)	0.01 Hz	7000H
U0-01	Set frequency (Hz)	0.01 Hz	7001H
U0-02	Bus voltage	0.1 V	7002H
U0-03	Output voltage	1 V	7003H
U0-04	Output current	0.01 A	7004H
U0-05	Output power	0.1 kW	7005H
U0-06	Output torque	0.1%	7006H
U0-07	DI state	1	7007H
U0-08	DO state	1	7008H
U0-09	AI1 voltage (V)	0.01 V	7009H
U0-10	AI2 voltage (V)/current (mA)	0.01 V/0.01 mA	700AH
U0-11	AI3 voltage (V)	0.01 V	7007BH
U0-12	Count value	1	700CH
U0-13	Length value	1	700DH
U0-14	Load speed	1	700EH
U0-15	PID setting	1	700FH
U0-16	PID feedback	1	7010H
U0-17	PLC stage	1	7011H
U0-18	Input pulse frequency (Hz)	0.01 kHz	7012H
U0-19	Feedback speed	0.01 Hz	7013H
U0-20	Remaining running time	0.1 Min	7014H
U0-21	AI1 voltage before correction	0.001 V	7015H
U0-22	AI2 voltage (V)/current (mA) before correction	0.01 V/0.01 mA	7016H
U0-23	AI3 voltage before correction	0.001 V	7017H
U0-24	Linear speed	1 m/Min	7018H
U0-25	Accumulative power-on time	1 Min	7019
U0-26	Accumulative running time	0.1 Min	701AH
U0-27	Pulse input frequency	1 Hz	701BH
U0-28	Communication setting value	0.01%	701CH
U0-29	Encoder feedback speed	0.01 Hz	701DH
U0-30	Main frequency X	0.01 Hz	701EH
U0-31	Auxiliary frequency Y	0.01 Hz	701FH

Function Code	Parameter Name	Min. Unit	Communication Address
Group U0: Standard Monitoring Parameters			
U0-32	Viewing any register address value	1	7020H
U0-35	Target torque	0.1%	7023H
U0-39	Target voltage upon V/F separation	1 V	7027H
U0-40	Output voltage upon V/F separation	1V	7028H
U0-41	DI state visual display	1	7029H
U0-42	DO state visual display	1	702AH
U0-43	DI function state visual display 1	1	702BH
U0-44	DI function state visual display 2	1	702CH
U0-45	Fault information	1	702DH

Chapter 6 Maintenance and Troubleshooting

6.1 Solutions to the faults of the H330

Fault Name	Display	Possible Causes	Solutions
Inverter unit protection	Err01	1: The output circuit is grounded or short circuited.	1: Eliminate external faults. 2: Install a reactor or an output filter. 3: Check the air filter and the cooling fan. 4: Connect all cables properly. 5: Contact the agent or our company.
		2: The connecting cable of the motor is too long.	
		3: The module overheats.	
		4: The internal connections become loose.	
		5: The main control board is faulty.	
		6: The drive board is faulty.	
		7: The inverter module is faulty.	
Overcurrent during acceleration	Err02	1: The output circuit is grounded or short circuited.	1: Eliminate external faults. 2: Perform the motor auto-tuning. 3: Increase the acceleration time. 4: Adjust the manual torque boost or V/F curve. 5: Adjust the voltage to normal range. 6: Select rotational speed tracking restart or start the motor after it stops. 7: Remove the added load. 8: Select an AC drive of higher power class.
		2: Motor auto-tuning is not performed.	
		3: The acceleration time is too short.	
		4: Manual torque boost or V/F curve is not appropriate.	
		5: The voltage is too low.	
		6: The startup operation is performed on the rotating motor.	
		7: A sudden load is added during acceleration.	
		8: The AC drive model is of too small power class.	
Overcurrent during deceleration	Err03	1: The output circuit is grounded or short circuited.	1: Eliminate external faults. 2: Perform the motor auto-tuning. 3: Increase the deceleration time. 4: Adjust the voltage to normal range. 5: Remove the added load. 6: Install the braking unit and braking resistor.
		2: Motor auto-tuning is not performed.	
		3: The deceleration time is too short.	
		4: The voltage is too low.	
		5: A sudden load is added during deceleration.	
		6: The braking unit and braking resistor are not installed.	

Fault Name	Display	Possible Causes	Solutions
Overcurrent at constant speed	Err04	<ol style="list-style-type: none"> 1: The output circuit is grounded or short circuited. 2: Motor auto-tuning is not performed. 3: The voltage is too low. 4: A sudden load is added during operation. 5: The AC drive model is of too small power class. 	<ol style="list-style-type: none"> 1: Eliminate external faults. 2: Perform the motor auto-tuning. 3: Adjust the voltage to normal range. 4: Remove the added load. 5: Select an AC drive of higher power class.
Overvoltage during acceleration	Err05	<ol style="list-style-type: none"> 1: The input voltage is too high. 2: An external force drives the motor during acceleration. 3: The acceleration time is too short. 4: The braking unit and braking resistor are not installed. 	<ol style="list-style-type: none"> 1: Adjust the voltage to normal range. 2: Cancel the external force or install a braking resistor. 3: Increase the acceleration time. 4: Install the braking unit and braking resistor.
Overvoltage during deceleration	Err06	<ol style="list-style-type: none"> 1: The input voltage is too high. 2: An external force drives the motor during deceleration. 3: The deceleration time is too short. 4: The braking unit and braking resistor are not installed. 	<ol style="list-style-type: none"> 1: Adjust the voltage to normal range. 2: Cancel the external force or install the braking resistor. 3: Increase the deceleration time. 4: Install the braking unit and braking resistor.
Overvoltage at constant speed	Err07	<ol style="list-style-type: none"> 1: The input voltage is too high. 2: An external force drives the motor during deceleration. 	<ol style="list-style-type: none"> 1: Adjust the voltage to normal range. 2: Cancel the external force or install the braking resistor.
Control power supply fault	Err08	The input voltage is not within the allowable range.	Adjust the input voltage to the allowable range.
Undervoltage	Err09	1: Instantaneous power failure occurs on the input power supply.	
		2: The AC drive's input voltage is not within the allowable range.	1: Reset the fault.
		3: The bus voltage is abnormal.	2: Adjust the voltage to normal range.
		4: The rectifier bridge and buffer resistor are faulty.	3: Contact the agent or our company.
		5: The drive board is faulty.	
6: The main control board is faulty.			
AC drive overload	Err10	<ol style="list-style-type: none"> 1: The load is too heavy or locked- rotor occurs on the motor. 2: The AC drive model is of too small power class. 	<ol style="list-style-type: none"> 1: Reduce the load and check the motor and mechanical condition. 2: Select an AC drive of higher power class.

Fault Name	Display	Possible Causes	Solutions
Motor overload	Err11	1: FA-01 is set improperly. 2: The load is too heavy or locked- rotor occurs on the motor. 3: The AC drive model is of too small power class.	1: Set FA-01 correctly. 2: Reduce the load and check the motor and the mechanical condition. 3: Select an AC drive of higher power class.
Power input phase loss	Err12	1: The three-phase power input is abnormal. 2: The drive board is faulty. 3: The lightening board is faulty. 4: The main control board is faulty.	1: Eliminate external faults. 2: Contact the agent or our company.
Power output phase loss	Err13	1: The cable connecting the AC drive and the motor is faulty. 2: The AC drive's three-phase outputs are unbalanced when the motor is running. 3: The drive board is faulty. 4: The module is faulty.	1: Eliminate external faults. 2: Check whether the motor three-phase winding is normal. 3: Contact the agent or our company.
Module overheat	Err14	1: The ambient temperature is too high. 2: The air filter is blocked. 3: The fan is damaged. 4: The thermally sensitive resistor of the module is damaged. 5: The inverter module is damaged.	1: Lower the ambient temperature. 2: Clean the air filter. 3: Replace the damaged fan. 4: Replace the damaged thermally sensitive resistor. 5: Replace the inverter module.
External equipment fault	Err15	1: External fault signal is input via DI. 2: External fault signal is input via virtual I/O.	Reset the operation.
Communication fault	Err16	1: The host computer is in abnormal state. 2: The communication cable is faulty. 3: F0-28 is set improperly. 4: The communication parameters in group FD are set improperly.	1: Check the cabling of host computer. 2: Check the communication cabling. 3: Set F0-28 correctly. 4: Set the communication parameters properly.
Contacting fault	Err17	1: The drive board and power supply are faulty. 2: The contactor is faulty.	1: Replace the faulty drive board or power supply board. 2: Replace the faulty contactor.
Current detection fault	Err18	1: The HALL device is faulty. 2: The drive board is faulty.	1: Replace the faulty HALL device. 2: Replace the faulty drive board.

Fault Name	Display	Possible Causes	Solutions
Motor auto-tuning fault	Err19	1: The motor parameters are not set according to the nameplate. 2: The motor auto-tuning times out.	1: Set the motor parameters according to the nameplate properly. 2: Check the cable connecting the AC drive and the motor.
EEPROM read-write fault	Err21	The EEPROM chip is damaged.	Replace the main control board.
Short circuit to ground	Err23	The motor is short circuited to the ground.	Replace the cable or motor.
Accumulative running time reached	Err26	The accumulative running time reaches the setting value.	Clear the record through the parameter initialization function.
User-defined fault 1	Err27	1: The user-defined fault 1 signal is input via DI. 2: User-defined fault 1 signal is input via virtual I/O.	Reset the operation.
User-defined fault 2	Err28	1: The user-defined fault 2 signal is input via DI. 2: The user-defined fault 2 signal is input via virtual I/O.	Reset the operation.
Accumulative power-on time reached	Err29	The accumulative power-on time reaches the setting value.	Clear the record through the parameter initialization function.
Load becoming 0	Err30	The AC drive running current is lower than F9-64.	Check that the load is disconnected or the setting of F9-64 and F9-65 is correct.
PID feedback lost during running	Err31	The PID feedback is lower than the setting of FA-26.	Check the PID feedback signal or set FA-26 to a proper value.
Pulse-by-pulse current limit fault	Err40	1: The load is too heavy or locked- rotor occurs on the motor. 2: The AC drive model is of too small power class.	1: Reduce the load and check the motor and mechanical condition. 2: Select an AC drive of higher power class.
Too large speed deviation	Err42	2: The motor auto-tuning is not performed. 3: FA-33 and FA-34 are set incorrectly.	1: Perform the motor auto-tuning. 2: Set FA-33 and FA-34 correctly based on the actual situation.
Communication fault between Keypad and control board	Err99	The keypad connection cable is loose or damaged. The keypad or the control board is damaged.	Reinsert the connection cable correctly. Replace the connection cable. Replace the keypad or control board.

6.2 Common Faults and Solutions

S N	Fault	Possible Causes	Solutions
1	There is no display at power-on.	1: There is no power supply to the AC drive or the power input to the AC drive is too low. 2: The power supply of the switch on the drive board of the AC drive is faulty. 3: The rectifier bridge is damaged. 4: The control board or the operation panel is faulty. 5: The cable connecting the control board and the drive board and the operation panel breaks.	1: Check the power supply. 2: Check the bus voltage. 3: Re-connect the 8-core and 28-core cables. 4: Contact the agent or our company for technical support.
2	The AC drive display is normal upon power-on. But the display is abnormal after running and stops immediately.	1: The cooling fan is damaged or locked-rotor occurs. 2: The external control terminal cable is short circuited.	1: Replace the damaged fan. 2: Eliminate external fault.
3	"Err23" is displayed at power-on.	1: The motor or the motor output cable is short-circuited to the ground. 2: The AC drive is damaged.	1: Measure the insulation of the motor and the output cable with a megger. 2: Contact the agent or our company for technical support.
4	Err14 (module overheat) fault is reported frequently.	1: The setting of carrier frequency is too high. 2: The cooling fan is damaged, or the air filter is blocked. 3: Components inside the AC drive are damaged (thermal coupler or others).	1: Reduce the carrier frequency (F0-20). 2: Replace the fan and clean the air filter. 3: Contact the agent or our company for technical support.
5	The motor does not rotate after the AC drive runs.	1: Check the motor and the motor cables. 2: The AC drive parameters are set improperly (motor parameters). 3: The cable between the drive board and the control board is in poor contact. 4: The drive board is faulty.	1: Ensure the cable between the AC drive and the motor is normal. 2: Replace the motor or clear mechanical faults. 3: Check and re-set motor parameters.

Chapter 7 Communication protocol

H330 drive supports modbus-RTU slave communication protocol, which has the following functions:

View and modify the parameters.

View various running status parameters.

Send run command and frequency reference to AC Drive from host computer.

7.1 About Modbus Communication Protocol

The protocol defines content and format of transmitted messages during serial communications, including master polling (or broadcasting) format and master coding method (function code for the action, transmission data, and error check). The slave uses the same structure in response, including action confirmation, data returning and error check. If an error occurs when the slave receives a message, or the slave can not complete the action required by the master, the slave returns a fault message as a response to the master.

7.2 Application

The AC drive is connected to a "single master multi-slave" PC/PLC control network with RS485 bus.

7.3 Bus Structure

(1) Interface mode

RS232/RS485 hardware .

(2) Topological structure

The system consists of a single master and multiple slaves. In the network, each communication device has a unique slave address. A device is the master (can be a PC, a PLC or an HMI) and initiates communication to perform parameter read or write operations on slaves. The other devices (slaves) provide data to respond to query or operations from the master. At the same moment, either the master or the slave transmits data and the other can only receive data.

The address range of the slaves is 1 to 247, and 0 is broadcast address. A slave address must be unique in the network.

(3) Transmission mode

The asynchronous serial and half-duplex transmission mode is used. During asynchronous serial communication, data is sent frame by frame in the form of message. In modbus-RTU protocol, an interval of at least 3.5-byte time marks the end of the previous message. A new message starts to be sent after this interval.

The communication protocol used by the drive is the Modbus-RTU slave communication protocol, which allows the drive to provide data to respond to "query/command" from the master or execute the action according to "query/command" from the master.

The master can be a PC, an industrial device, or a PLC. The master can communicate with a single slave or send broadcast messages to all slaves. When the master communicates with a single slave, the slave needs to return a message (response) to "query/command" from the master.

For a broadcast message sent by the master, the slaves need not return a response.

7.4 Data Format

The drive supports reading and writing of word-type parameters only. Reading command is 0x03 and writing command is 0x06. It does not support reading and writing of bytes or bits .

The modbus-RTU protocol communication data format of the drive is as follows:

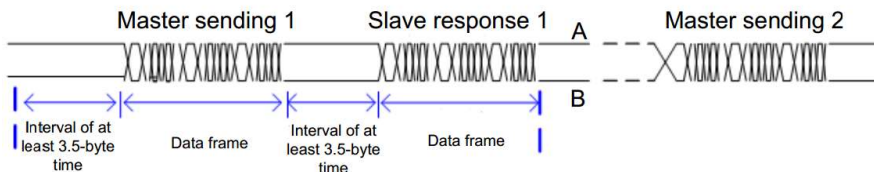

In theory, host computer can read several consecutive parameters (n can reach up to 12) but the last parameter it reads must not jump to the next parameter group. Otherwise, an error occurs on response.

RTU Frame Format:

Frame header (START)	3.5 byte of idle time
Slave Address (ADR)	1~247
Command code (CMD)	03: Read; 06: Write
Data (N-1)	Number of byte (2n)
Data (N-2)	
.....	
Data (0)	
CRC Check Low bytes	2 bytes
CRC Check High bytes	
END	3.5 byte of idle time

For example, read 2 function code value (address start at F002) from the drive (slave address is 01) :

Master Query Frame Information

Slave Address (ADR)	01H
Command code (CMD)	03H
Function code start address(H)	F0H
Function code start address(L)	02H
Number of function codes (H)	00H
Number of function codes (L)	02H
CRC CHK (L)	To be calculate
CRC CHK (H)	

Slave Response Frame Information

FC-05 is set to 0:

ADR	01H
CMD	03H
Data byte number (H)	00H
Data byte number (L)	04H
Data(F002) value (H)	00H
Data(F002) value (L)	00H
Data(F003) value (H)	00H
Data(F003) value (L)	01H
CRC CHK (L)	To be calculate
CRC CHK (H)	

FC-05 is set to 1:

ADR	01H
CMD	03H
Data byte number	04H
Data(F002) value (H)	00H
Data(F002) value (L)	00H
Data(F003) value (H)	00H
Data(F003) value (L)	01H
CRC CHK (L)	To be calculate
CRC CHK (H)	

For example, write value 5000 (1388H) to function code F00A of the drive (slave address is 02H)

Master Query Frame Information

ADR	02H
CMD	06H
Parameter address (H)	F0H
Parameter address (L)	0AH
Parameter value (H)	13H
Parameter value (L)	88H
CRC CHK (L)	To be calculate
CRC CHK (H)	

Slave Response Frame Information

ADR	02H
CMD	06H
Parameter address (H)	F0H
Parameter address (L)	0AH
Parameter value (H)	13H
Parameter value (L)	88H
CRC CHK (L)	To be calculate
CRC CHK (H)	

7.5 Definition of Communication Parameter Addresses

Read and written parameters

Function parameters can be read and written (except those which cannot be changed because they are only for the factory use or for monitoring).

Parameter group No. and parameter identifying No. are used to express parameter address.

High-order bytes: F0-FF(groups F), 70-7F(group U)

Low-order bytes: 00-FF

For example, to read parameter F3-12, communication address of F3-12 is expressed as 0xF30C.

Note:

Group FF: They are factory parameters. The parameters cannot be read or changed.

Group U: These parameters can only be read.

Some parameters cannot be modified when the AC drive is running. Some parameter cannot be modified regardless of status of AC drive. In addition, pay attention to setting range, unit and description of parameters when modifying them.

Frequent storage to EEPROM reduces its service life. Therefore, in communication mode, users can change values of certain parameters in RAM rather than storing the setting. For groups F parameters, users only need to change high order F of the function code address to 0.

For example, if function code F3-12 is not stored into EEPROM, the address is expressed as

030C;

Stop/RUN Parameters:

Para. Address	Description
1000	Communication setting value (-10000~10000) (Decimal)
1001	Running frequency
1002	Bus voltage
1003	Output voltage
1004	Output current
1005	Output power
1006	Output torque
1007	Running speed
1008	DI input indication
1009	DO output indication
100A	AI1 voltage
100B	AI2 voltage
100C	Operation panel potentiometer (AI3) voltage
100D	Counting value input
100E	Length value input
100F	Load speed
1010	PID reference
1011	PID feedback
1012	PLC process
1013	Pulse input frequency, unit 0.01kHz
1014	Feedback speed, unit 0.1Hz
1015	Remaining running time
1016	AI1 voltage before correction
1017	AI2 voltage before correction
1018	Operation panel potentiometer (AI3) voltage before correction
1019	Linear speed
101A	Current power-on time
101B	Current running time
101C	Pulse input frequency, unit 1Hz
101D	Communication reference
101E	Actual feedback speed
101F	Main frequency reference display
1020	Auxiliary frequency reference display

Note:

Communication setting value indicates percentage: 10000 corresponds to 100.00%, and -10000 corresponds to -100.00%.

With regard to frequency, communication reference is a percentage of F0-09 (maximum frequency).

Control command input to AC drive: (write-only)

Command word address	Command word function
2000H	0001: Forward run
	0002: Reverse run
	0003: Forward jog
	0004: Reverse jog
	0005: Coast to stop
	0006: Decelerate to stop
	0007: Fault reset

Read AC drive state : (read-only)

Command word address	Command word function
3000H	0001: Forward run state
	0002: Reverse run state
	0003: stop state

Parameter lock password check:

(if “8888H” is returned, it indicates that password check is passed)

Password Address	Password Content
1F00H	*****

DO terminal control: (write-only)

Command Address	Command Content
2001H	BIT0: DO1 control BIT1: DO2 control BIT2: RELAY1 control BIT3: RELAY2 control BIT4: FMR control BIT5: VDO1 BIT6: VDO2 BIT7: VDO3 BIT8: VDO4 BIT9: VDO5

AO1 control: (write-only)

Command Address	Command Content
2002H	0~7FFF indicates 0%~100%

AO2 control: (write-only)

Command Address	Command Content
2003H	0~7FFF indications 0%~100%

Pulse output control: (write-only)

Command Address	Command Content
2004H	0~7FFF indications 0%~100%

AC drive fault description:

AC Drive Fault Address	AC Drive Fault Information
8000H	0000: No fault 0001: Reserved 0002: Over current during acceleration 0003: Over current during deceleration 0004: Over current at constant speed 0005: Over voltage during acceleration 0006: Over voltage during deceleration 0007: Over voltage at constant speed 0008: Buffer resistor overload 0009: Under voltage 000A: AC drive overload 000B: Motor overload 000C: Power input phase lost 000D: Power output phase lost 000E: IGBT overheat 000F: External fault 0010: Communication fault 0011: Contactor fault 0012: Current detection fault 0013: Motor auto-tuning fault 0015: EEPROM fault 0016: AC drive hardware fault 0017: Motor short circuit to earth 001A: Accumulative running time reached 001B: User define fault 1 001C: User define fault 2 001D: Accumulative power-on time reached 001E: load lost 001F: PID feedback lost during running

	0028: Fast current limit timeout
--	----------------------------------

Communication Fault Description (Error Code) :

Communication Fault Address	Fault Description
8001H	0000: No fault 0001: Password is uncorrected 0002: Command word is uncorrected 0003: CRC check word is uncorrected 0004: Address is invalid 0005: The parameter is invalid 0006: Can not change the parameter 0007: AC drive is lock 0008: AC drive is processing EEPROM

Warranty Agreement

1. The warranty period of the product is 18 months (refer to the barcode on the equipment). During the warranty period, if the product fails or is damaged under the condition of normal use by following the instructions, our company will be responsible for free maintenance.
2. Within the warranty period, maintenance will be charged for the damages caused by the following reasons:
 - a. Improper use or repair/modification without prior permission
 - b. Fire, flood, abnormal voltage, other disasters and secondary disaster
 - c. Hardware damage caused by dropping or transportation after procurement
 - d. Improper operation
 - e. Trouble out of the equipment (for example, external device)
3. If there is any failure or damage to the product, please correctly fill out the Product Warranty Card in detail.
4. The maintenance fee is charged according to the latest Maintenance Price List of our company.
5. The Product Warranty Card is not re-issued. Please keep the card and present it to the maintenance personnel when asking for maintenance.
6. If there is any problem during the service, contact our company's agent or our company directly.

Product Warranty Card

Customer information	Add. of unit:	
	Name of unit:	Contact person:
	P.C.:	Tel.:
Product information	Product model:	
	Body barcode (Attach here):	
	Name of agent:	
Failure information	(Maintenance time and content):	
	Maintenance personnel:	